



AE-PDV21-3

Priority Demand Valve v3



Key Features:

- Flow & level switch Input to activate PDV
- Failsafe operation closes the PDV in the event of a power cut
- Manual reset button to ensure system inspection after activation
- If the system fault remains unresolved after a manual reset, the PDV will activate again to prevent resetting when it is not safe
- Time delay function to prevent false activation without the need for expensive time delay flow switch
- Built-in sounder beacon to alert upon activation
- Volt-free output can be used as a fire output, triggered solely by a flow switch signal

Applications Engineering’s BS 9251:2021-compliant Priority Demand Valve (PDV) assembly is designed to activate upon receiving a signal from a flow or level switch. Once activated, the valve automatically shuts off the domestic water supply, diverting all water to the sprinkler system.

The priority demand valve is available in various sizes and comes with either an actuated ball valve (sizes ½” - 2”) or butterfly valve with an electric actuator (sizes 2 ½” - 8”) along with a 230v Relay box.



Size	Part Number	Valve Type
1/2"	AE-PDV21-2-050	Actuated Ball Valve
3/4"	AE-PDV21-2-075	Actuated Ball Valve
1"	AE-PDV21-2-100	Actuated Ball Valve
1 1/4"	AE-PDV21-2-125	Actuated Ball Valve
1 1/2"	AE-PDV21-2-150	Actuated Ball Valve
2"	AE-PDV21-2-200	Actuated Ball Valve
2 1/2"	AE-PDV21-2-250	Butterfly Valve
3"	AE-PDV21-2-300	Butterfly Valve
4"	AE-PDV21-2-400	Butterfly Valve
5"	AE-PDV21-2-500	Butterfly Valve
6"	AE-PDV21-2-600	Butterfly Valve
7"	AE-PDV21-2-700	Butterfly Valve
8"	AE-PDV21-2-800	Butterfly Valve

AE-PDV21-3

Priority Demand Valve v3

Wiring

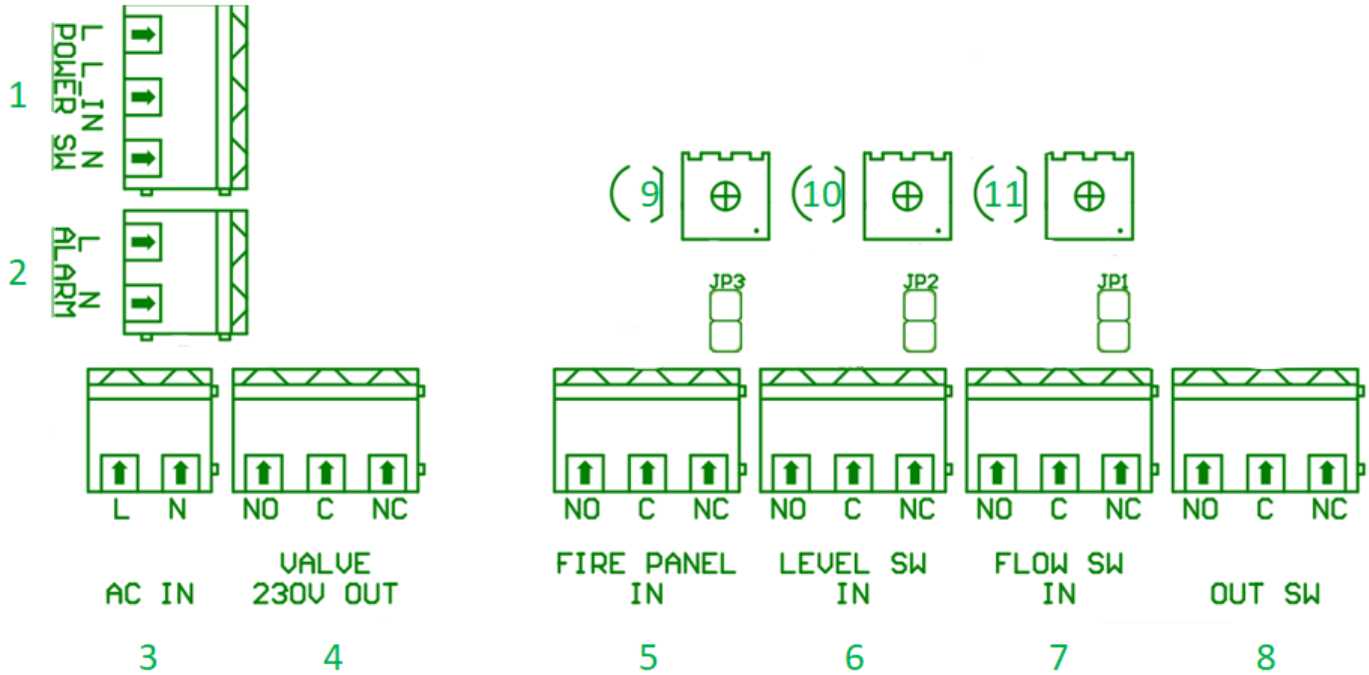

- | | |
|--|--|
| <ol style="list-style-type: none"> 1. Pre-wired output to Reset Button 2. Pre-wired output to sounder beacon 3. 230v Mains Power input 4. Output to actuator – use ‘C’ & ‘NC’ terminals 5. Fire Panel Input - remove jumper (JP3) for NC input 6. Low level Input - remove jumper (JP2) for NC input | <ol style="list-style-type: none"> 7. Flow Switch Input - remove jumper (JP1) for NC input 8. Volt free contact (for external alarm) 9. Adjustable time delay 1 – for fire panel input 10. Adjustable time delay 2 – for low level input 11. Adjustable time delay 3 – for flow switch input <p>*Turn clockwise to increase time delay.</p> |
|--|--|

The actuator comes pre-wired with a 2 core cable, there is no need to go inside the actuator, this 2 core cable just needs to be wired into Valve 230V Out in the relay, ‘C’ & ‘NC’ connections.

Wiring Notes

- Fitted with a 4A removable fuse.
- The “Valve 230V Out” is a powered output. For BS 9251:2021 compliance, simply connect the actuator’s two wires to the “C” and “NC” terminals in the relay box. Wiring is not polarity sensitive.
- Inputs (fire panel, level switch, and flow switch) expect a normally open signal. For normally closed switches, wire to the common and NC terminals and remove the jumper above the input.
- Do not use the flow switch input if connecting through another panel.

AE-PDV21-3

Priority Demand Valve v3

Wiring Notes

- The Fire panel input is strictly for use when the activation signal is coming from a fire panel. This is because the fire panel will have a latched relay and so the manual reset to be compliant to BS9251:2021 will take place at the panel.
- You do not need to use both the Flow switch input and Fire panel input , only one is necessary.
- The Time Delays are pre-set to 10-15 seconds.

Installation Notes

- We recommend fitting a small-bore bypass valve in parallel to the PDV to allow limited water supply (e.g., for drinking or toilet flushing) in the event of power failure. This valve should remain closed during normal operation.
- The actuator can be removed for manual valve override if power fails.
- When any input is triggered, the sounder beacon activates and the valve closes. For flow switch inputs, a manual reset (power cycle) is required. If the fault persists, the alarm will trigger again.
- The fire panel input auto-resets, as the panel itself handles manual reset per BS 9251:2021.
- When performing a manual reset, switch the power switch off and leave it for 10 seconds before turning back on, allowing for the system to reset. Not allowing for this time will not reset the PDV.
- The OUT SWITCH is a volt-free output used only when a signal comes from the flow switch. It stops alarming when the flow switch deactivates, but manual reset is still required to return the PDV to a working state.

AE-PDV21-3

Priority Demand Valve v3

Actuated Ball Valve Information

- Screwed BSP Parallel
- PTFE Seals
- Full Bore
- Remove actuator for manual override
- Suitable for potable water

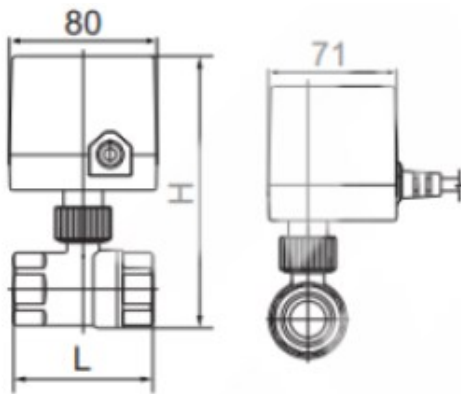

DN	L	H	Kv
½"	55	124	10
¾"	62	130	15
1"	71	135	23
1 ¼"	75	142	31
1 ½"	89	152	38
2"	101	164	38

Materials	
Outer Body	Brass
Inner Ball	Stainless 304
Seals	PTFE
Technical Data	
Medium Temperature	0°C to 130°C
Ambient Temperature	0°C to 65°C
Max. Pressure	16 Bar
Medium	Water
Drive Voltage	220 VAC
Protection Class	IP54

Butterfly Valve Information

Butterfly Valve Technical data:

Maximum Pressure 16 Bar Working

	50	65	80	100	125	150	200	250	300
A	142	154.5	161	180	193	205	250	282	326
B	60	70	85	104	120	135	171	205	248
D	125	145	160	180	210	240	295	350	400
D1	125	145	160	180	210	240	295	350	410
D2	120	139.7	152.4	190.5	215	241	298.	361	431
	.7				.9	.3	5	.9	.8

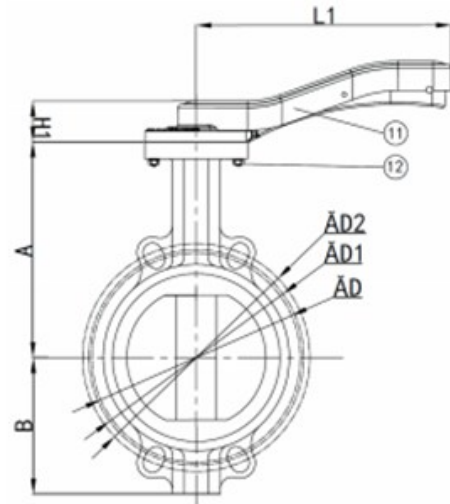

N.	Part Name	Material
1	Body	Ductile Iron GGG40
2	Disc	Stainless Steel 316
3	Seat	WRAS EPDM
4	Upper Shaft	Stainless Steel 420
5	Lower Shaft	Stainless Steel 420
6	Bushing	PTFE
7	Split Pin	Spring Steel 65Mn
8	Circlip	Spring Steel 65Mn
9	O-ring	WRAS EPDM
10	Ring	Nylon 6 PA6
11	Lever	DN50-150 Aluminium DN200-300 D
12	Bolt	Stainless Steel 304
13	Body	Ductile Iron GGG40