



## AE VS-A-M2 - 1 1/2" & 2" Monitored Dual Port Fire Sprinkler Valve Set



**BS 9251:2021**



**CE**

2831-CPR-S0095

### Features

- Monitored full bore isolation valve compliant to BS 9251: 2021
- AEL VKS JB flow switch LPCB approved to EN 12259-5
- Dual ports that enable the flow switch to be mounted on either side
- AEL VKS JB flow switch which has been designed specifically for the valve set to operate at 25 L/min
- The flow switch has a 3/4" union nut for simple, hand tight installation no need for tools or awkward 360° rotation of the whole switch
- 1" Top port allows a Potter flow switch to be mounted
- 100% pressure tested.
- Lockable inlet valve handle
- Full bore test valve
- Glycerine filled 16 bar pressure gauge
- Easy access for servicing
- Less joints minimise risk of leaks

Applications Engineering dual port monitored fire sprinkler valve set has been specifically designed for the residential and Domestic market, using our AE VKS-JB switch that has been specifically designed to activate at 25 l/min. The monitored Ball valve can be retro fitted and using our unique design also gives the option to monitor to the flow switch.



A full range of fittings and adaptors can be fitted and sealed in house by our team to any of our Valves & Valve sets, additional & Bespoke attachments can be fitted on request.



# AE VS-A-M2 - 1 1/2" & 2" Monitored Dual Port Fire Sprinkler Valve Set

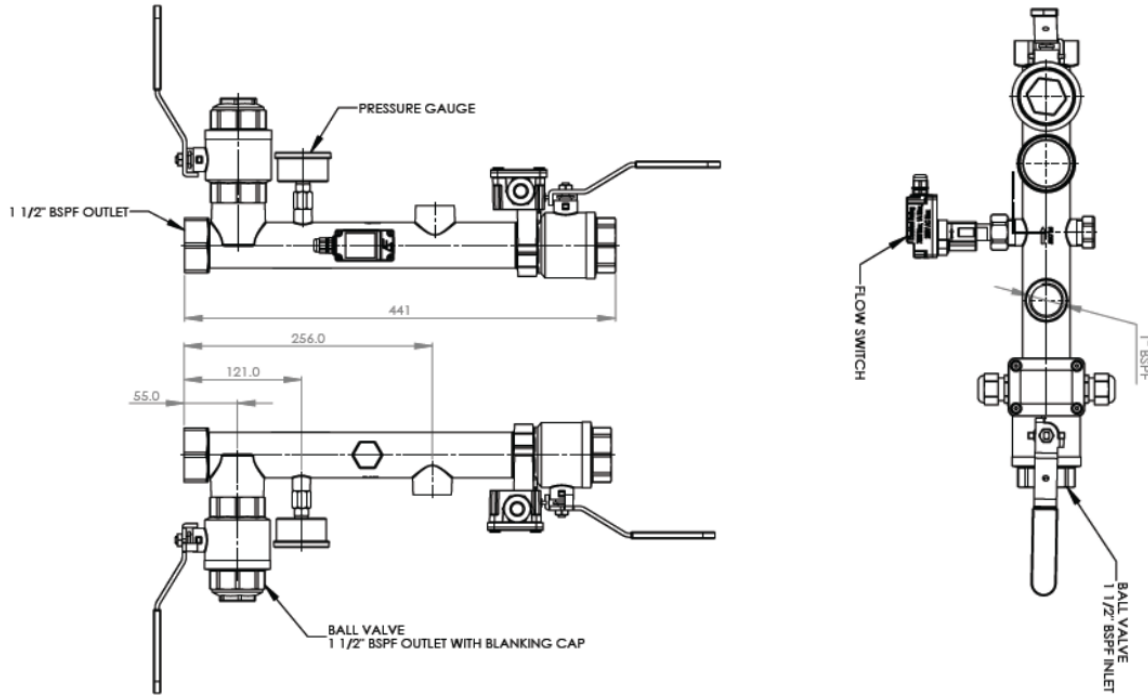

Order Number	Description
AE VS3-A-M2	DN40 (1 1/2") Dual Port Valve set with Monitored Ball Valve pre-wired
AE VS4-A-M2	DN50 (2") Dual Port Valve set with Monitored Ball Valve pre-wired
AE VS3-A-BB-M2	DN40 (1 1/2") Dual Port Valve set with Monitored Ball Valve pre-wired & CPVC on inlet and outlet
AE VS4-A-BB-M2	DN50 (2") Dual Port Valve set with Monitored Ball Valve pre-wired & CPVC on inlet and outlet
AE VS3-A-C-M2	DN40 (1 1/2") Dual Port Valve set with Monitored Ball Valve pre-wired & Single Check Valve on Inlet
AE VS4-A-C-M2	DN50 (2") Dual Port Valve set with Monitored Ball Valve pre-wired & Single Check Valve on Inlet

Technical Data	
Pressure Rating (Manifold)	PN16
Medium Temperature	100°C Max
Ambient Temperature	80°C Max
Flow Switch Protection Class	AEL – IP64
Switching Current	AEL - Max 1 A
Switching voltage	Max 250 VAC
Contacts	AEL – SPST

\*Many more options available, just ask a member of the team for details

Optional Keyed alike padlock compatible with all AEL Valves & Valve Sets.

Ordering code: AE-PAD-1



# AE VS-A-M2 - 1 1/2" & 2" Monitored Dual Port Fire Sprinkler Valve Set

## Installation of Monitor

All Applications Engineering monitored ball valves come pre-fitted and wired, eliminating the need for on-site installation, however, the below instructions can be used for retro-fitting a monitor onto an existing Applications Engineering ball valve.

**IMPORTANT NOTE** - Applications Engineering monitors can only be used on Applications Engineering ball valves, this is due to the positioning of the handle and clamp. Monitors fitted to other ball valves are not covered by warranty and we can't be held responsible for faults.

The latest versions of the Applications Engineering ball valves come with an integrated clamp within the valve, eliminating the use of the retro-fitted two part plastic clamps used on previous version, these are still compatible with the current monitors

To attach the monitor to the valve, use the locating lugs on the bottom of the monitor to fit onto the two locating holes on the top of the clamp. Then, using the two captive screws within the monitor housing, screw both into the corresponding screw holes within the clamp, ensuring the monitor is secure.

Ensure the ball valve is fully open and the toggle is fully engaged against the handle when housing is secure, as per figure 1, any movement from this position will result in an activation.

After wiring as required, secure the lid to the MBV housing with the four captive screws in the lid.

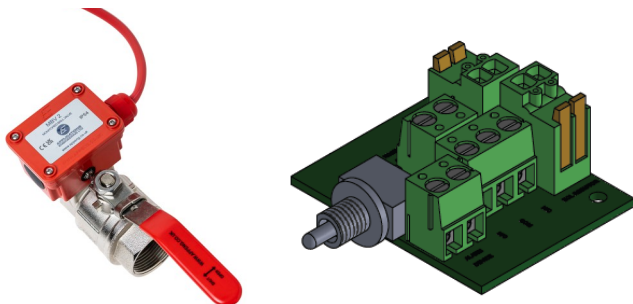
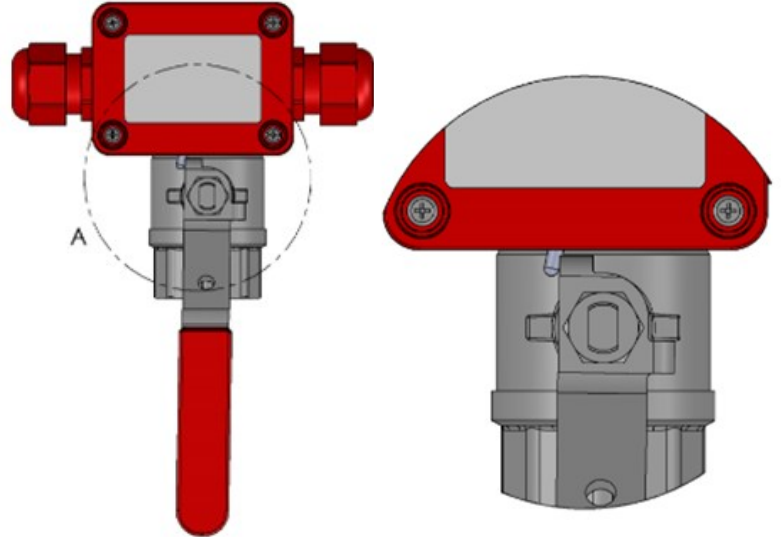
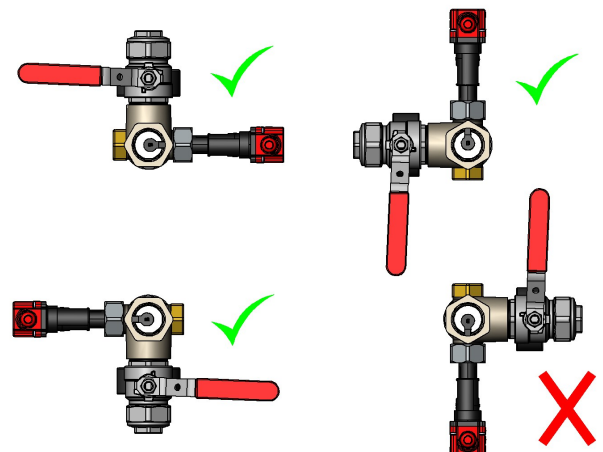

Figure 1



The Monitor is a 1-piece construction that makes mounting easy and fully retrofittable to any Applications Engineering ball valve or valve set. The housing can be easily screwed into place from the top into the pre-moulded clamps.

## Flow Switch Installation Orientation



- **NEVER ALLOW FLOW SWITCH ORIENTATION TO DROP BELOW 90° FROM UPRIGHT POSITION**
- **Ensure that the flow direction arrows on both the valve set and top of flow switch align**

# AE VS-A-M2 - 1 1/2" & 2" Monitored Dual Port Fire Sprinkler Valve Set

## Monitored Valve Set Wiring Instructions:

Applications Engineering Monitored valve sets come pre-wired with two lengths of FP200 cable, 1/2m into the flow switch and a 1m flying lead.

A time delay should be programmed in the alarm panel from 5-30 seconds to prevent false activations.

There are two different wiring configurations to suit all situations.

### Monitoring Flow Switch and Monitored Ball Valve as one Output (This is how they come pre-wired)

- Wire the 1m flying lead from the 'ALARM DEVICE' terminal into the zone on the fire panel. The flow switch is pre-wired into the terminal marked 'FLOW SWITCH'.

- Insert an EOL resistor and FIRE resistor into the corresponding lever terminals. Ensure use of the panel's correct resistor value terminals for full circuit supervision.

- The panel will then signal fault when the ball valve handle is moved or signal fire in the event of an activation of the flow switch.

- Ensure the isolation valve is locked in the fully open position. In this position, the circuit will be running at the panel's resistor value when the isolation valve is fully open.

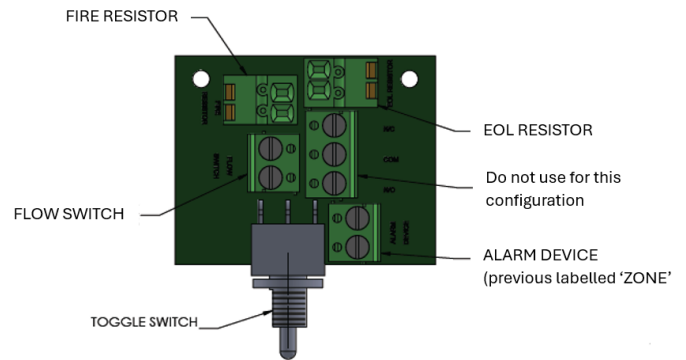

SYSTEM SCHEMATIC

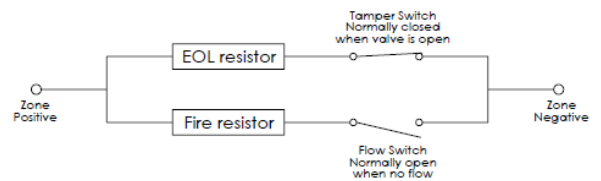

### Monitoring the flow switch and isolation valve as separate outputs

- Remove the flow switch cable from the 'FLOW SWITCH' terminal and take straight to alarm panel.

- Remove the 1m flying lead from the 'ALARM DEVICE' terminal and rewire to the common/normally open or common normally closed terminals, depending on preference.

- To monitor fault and activation of each device, install an EOL & ALARM resistor within the flow switch and monitor output terminals separately. Each panel manufacturer require different resistor values, ensure use of the panel's correct resistor value for circuit supervision.

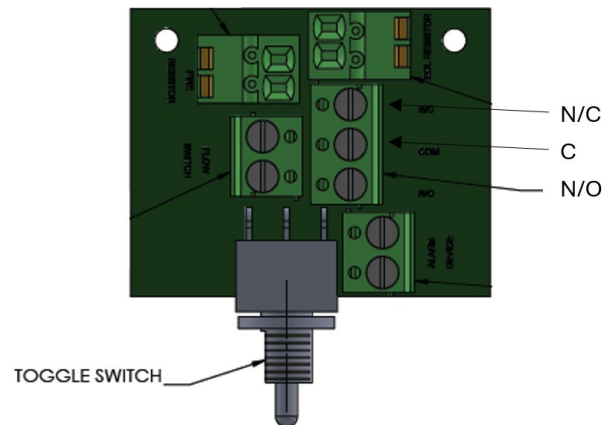

## Maintenance

All Applications Engineering valves & monitored ball valves requires no regular maintenance, however, it is advisable to inspect and ensure proper operation of the unit annually.

# AE VS-A-M2 - 1 1/2" & 2" Monitored Dual Port Fire Sprinkler Valve Set

## Time Delay Instructions:

The AE-VKS JB range of flow switches does not come with an inbuilt time delay to remain as compact as possible, this is to be programmed in the alarm device.

Fire panels will have one of the following time delay features;

- Electrical time delay – this is a fully adjustable time delay and will be programable in the settings. Within the settings you can programme the exact delay you want from 3-30 seconds, we would recommend a delay of around 10 seconds to prevent false activations.
- Mechanical time delay – this will be a physical switch within the panel that is manually activated and will add a fixed time delay of roughly 30 seconds.

If you are unsure of what type of delay your panel has, contact the manufacturer who will be able to advise.

## Flow Switch Installation:

**Installation:** AEL VKS-JB is the easiest flow switch to install on the market, the integrated O-ring means no sealing is required, just hand tighten the 3/4" BSP female thread on the flow switch into one of the 3/4" male dual ports.

A brass cap and washer are supplied fitted to one of the dual ports, ensure that both are fitted and tightened to the port not being used for the flow switch. Use without washer or cap not tightened properly will result in leaks.

To ensure the manifold is securely positioned, bracket within 150mm from top and bottom connections

**Signal Testing:** A signal test can be manually activated to ensure a signal is being sent and received by the alarm device. Place a magnet against the back stem of the flow switch, this is where the read switch is located and will simulate a paddle activation

**Maintenance:** Inspect switches monthly for leaks. If leaks are found, replace the switch. AE-VKS JB water flow switch should

