

# ART 681 M & F

## Bronze / Gunmetal Pressure Reducing Valve

### Features

- Standard threaded connections:
  - Male thread BSP-T / Male thread BSP-T
- Version with female thread (available in sizes DN15, DN20 and DN25):
  - Female thread BSP-P / Female thread BSP-P
- Body gunmetal
- Suitable for neutral and non-neutral liquids, air, gases, vapours and warm water
- WRAS Approved
- DIN DVGW guidelines, DIN EN 1567, ISO 3822, PED 2014/68/EU
- Marine Approvals - GL, LR EMEA, BV, ABS, RS
- ATEX Approval Available at Extra Cost
- 24 Month Warranty
- Test Certificate to EN10204-3.1 Available on Request

### Typical Applications

- Potable water supply according to DIN 1988
- Process water supply in industrial- and building technology
- Snow-making equipment
- Fire-fighting equipment and sprinkler systems
- Shipbuilding industry and offshore plants

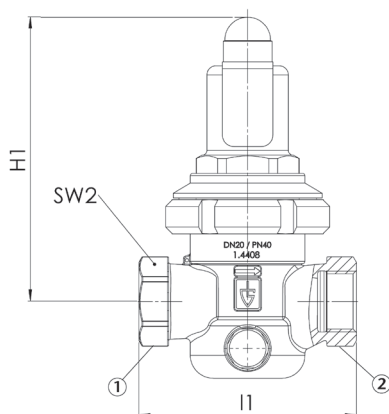
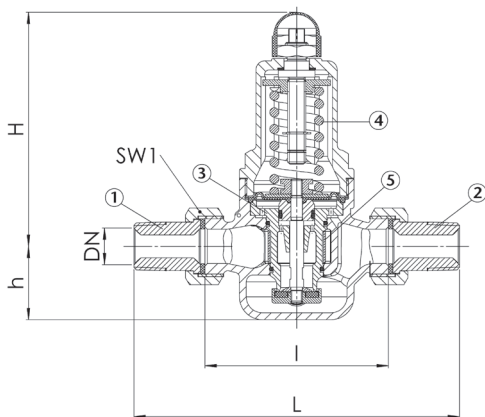

### Technical Data

Inlet pressure:	Up to 40 bar
Outlet pressure:	0,5 to 15 bar
Working Temperature	EPDM or FKM Seal -10°C to +95°C

Dimensions in mm

This data sheet is designed as a guide and should not be regarded as wholly accurate in every detail. We reserve the right to amend the specification of any product without notice.

Connection	DN	1/2"	3/4"	1"	1 1/4"	1 1/2"	2"
Inlet pressure SP, HP up to	bar	40	40	40	40	40	40
Inlet pressure LP to	bar	25	25	25	25	25	25
Outlet pressure	bar	0.5 - 2	0.5 - 2	0.5 - 2	0.5 - 2	0.5 - 2	0.5 - 2
		1 - 8	1 - 8	1 - 8	1 - 8	1 - 8	1 - 8
		5 - 15	5 - 15	5 - 15	5 - 15	5 - 15	5 - 15
Installation dimensions	L	142	158	180	193	226	252
	in mm						
	I	80	90	100	105	130	140
	I1	85	95	105			
	H (H1)	102 (128 <sup>1</sup> )	102 (128 <sup>1</sup> )	130 (150 <sup>1</sup> )	130 (150 <sup>1</sup> )	165 (185 <sup>1</sup> )	165 (185 <sup>1</sup> )
	h	33	33	45	45	70	70
	SW1	30	37	46	52	65	75
	SW2	28	35	43	48	57	68
Weight	kg	1.2	1.3	2.4	2.6	5.5	6.0
		(1.5 <sup>1</sup> )	(1.6 <sup>1</sup> )	(2.9 <sup>1</sup> )	(3.1 <sup>1</sup> )	(6.2 <sup>1</sup> )	(6.7 <sup>1</sup> )
Coefficient of flow kvs	m <sup>3</sup> /h	3	3.5	6.7	7.6	12.5	15

<sup>1</sup> for type 681mGFO-LP

<sup>2</sup> The kvs value was determined according to DIN EN 60534-2-3. Instructions on how to determine size and capacity are to be found under section 2.

N.	Part Name	Materials
1	Inlet body	Bronze / Gunmetal CC499K
2	Outlet body	Bronze / Gunmetal CC499K
3	Internal parts	Bronze / Gunmetal CC499K Stainless Steel 1.4404
4	Spring	Spring steel with anti-rust protection 1.1200
5	Strainer	Stainless Steel 1.4404

# ART 681 M & F

## Valve version

m	with diaphragm	High-quality, heat-resistant moulded elastomere, fabric-reinforced diaphragm. Pressure adjustment by means of non-rising spindle. Valve insert with balanced single seat valve completely made of stainless steel.
Complete valve insert SP/HP (order code: 681 Insert-DN...-seal) available as replacement part can be exchanged without removing the valve.		
Complete valve insert LP (order code: 681 LP Insert-DN...-seal) available as replacement part can be exchanged without removing the valve.		
Built-in dirt trap made of stainless steel.		
Mesh size:	DN 15 to DN 32	0,60 mm
	DN 40 and DN 50	0,75 mm

## Medium

GF	gaseous and liquid	for water and distilled water, neutral and non-sticking liquids, compressed air and neutral gases; optionally with FPM elastomere seals for non-neutral media i.e. oils, fuels, oil-laden compressed air etc.
----	--------------------	---

## Type of lifting mechanism

O	without lifting device
---	------------------------

## Outlet pressure ranges

SP	Standard version	Inlet pressure: up to 40 bar	Outlet pressure: from 1 to 8 bar
HP	High-pressure version	Inlet pressure: up to 40 bar	Outlet pressure: from 5 to 15 bar
LP	Low-pressure version	Inlet pressure: up to 25 bar	Outlet pressure: from 0,5 to 2 bar
<b>Fixed setting at a required outlet pressure against surcharge.</b>			

## Seat-Seal/Diaphragm Options

Option	Materials	Type	Working Temp.
EPDM	Ethylene propylene diene	Elastomere moulded diaphragm and seals approvals according to drinking water directive	-10°C to +95°C
Against surcharge			
FKM	Fluorocarbon	Elastomere moulded diaphragm and seals	-10°C to +95°C

## Capacity charts

### Art 681 M & F

Dimensioning by pressure loss on the outlet pressure side

#### Flow chart water

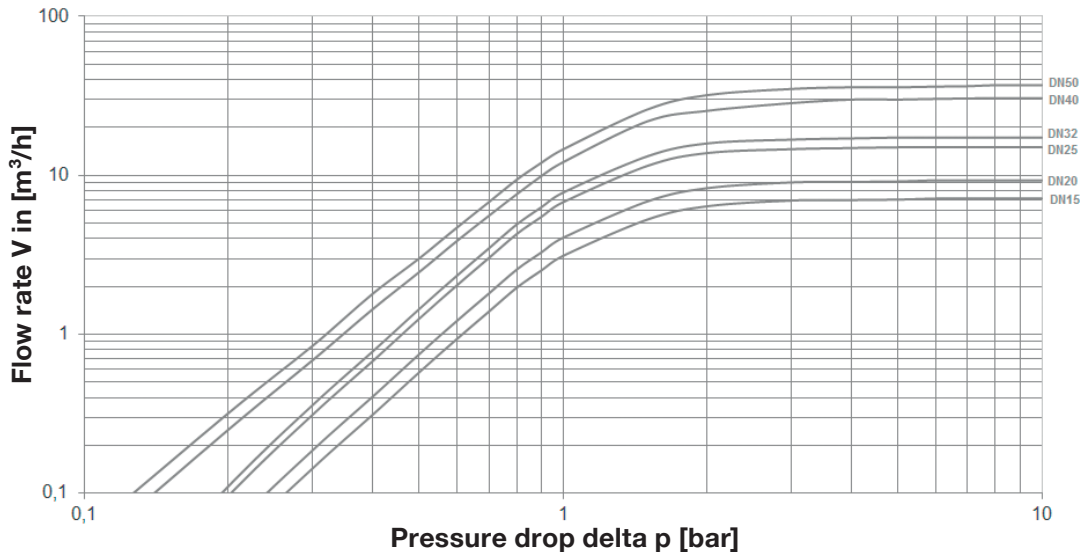

#### Dimensioning by flow velocity

##### For Liquids:

With help of the chart you can determine the nominal diameter (DN) for a given flow volume V (m³/h). According to DVGW-guidelines (DIN 1988) a flow velocity of 2 m/s in domestic water supply systems should not be exceeded.

##### For compressed air and other gaseous media:

The usual flow velocity for compressed air is 10 - 20 m/s. For gaseous media the flow volume V should always be shown in actual cubic meters/hour.

If the flow volume is given in standard cubic meters, these should be converted into actual cubic meters before using the diagram.

$$V (\text{m}^3/\text{h}) = \frac{V_{\text{Norm}} (\text{Nm}^3/\text{h})}{p_{\text{absolut}} (\text{bar})} = \frac{V_{\text{Norm}}}{p_0 + 1}$$

Actual cubic meters are based on the prevailing pressure of the medium on the outlet side of the pressure reducer.

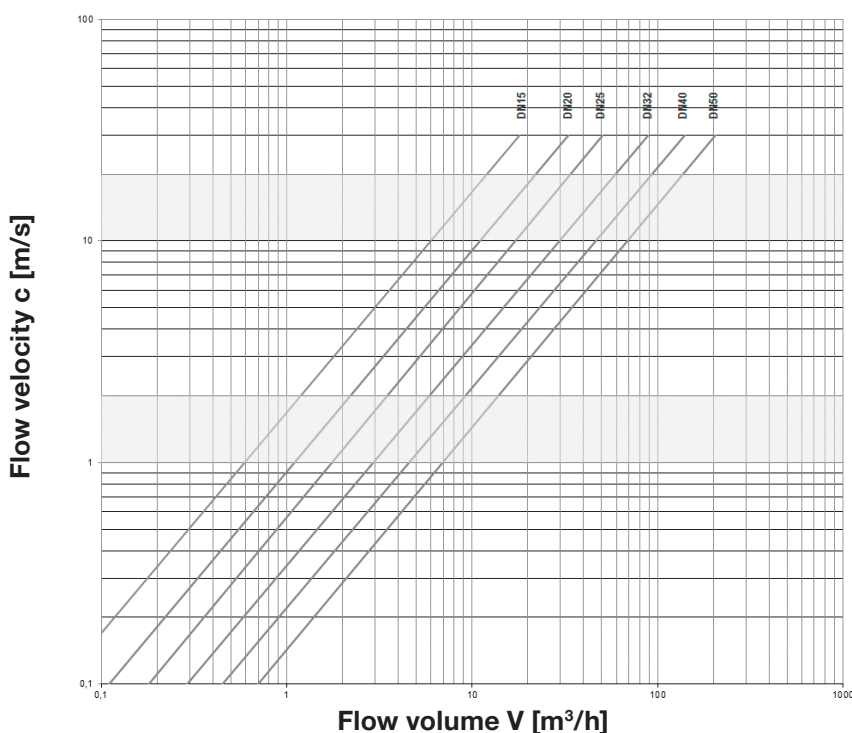

Dimensions in mm

This data sheet is designed as a guide and should not be regarded as wholly accurate in every detail. We reserve the right to amend the specification of any product without notice.