



1 1/2" & 2" MONITORED FIRE SPRINKLER VALVE SET



Features

- Dual ports that enable the AEL compact flow switch to be mounted on either side.
- 1" Top port allows a Potter flow switch to be mounted
- Uses choice of flow switch:
 - AEL flow switch which has been designed specifically for the valve set to operate at 25 L/min
 - Potter VSR-S Series designed for metal pipe with adjustable time delay
- AEL flow switch has a 3/4" union nut for simple, hand tight, installation.
No need for tools or awkward 360° rotation of the whole switch.
- 100% pressure tested.
- Lockable inlet valve handle
- Full bore test valve
- Glycerine filled 16 bar pressure gauge
- Easy access for servicing
- Less joints minimise risk of leaks

Applications Engineering Dual port fire sprinkler valve set has been specifically designed for the residential & Domestic market, using our own flow switch that has been specifically designed for the valve set to activate at 25 l/min. A monitored Ball valve can be retro fitted and using our unique design also gives the option to monitor to the flow switch



We also supply a full range of WRAS approved check valves, CPVC and MDPE adaptors along with many other extras



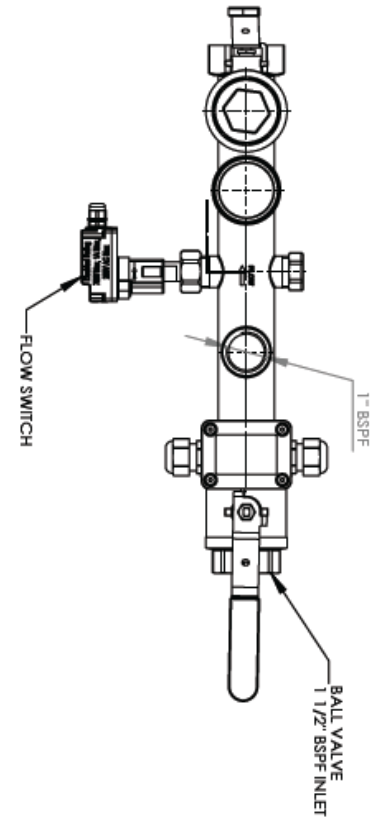
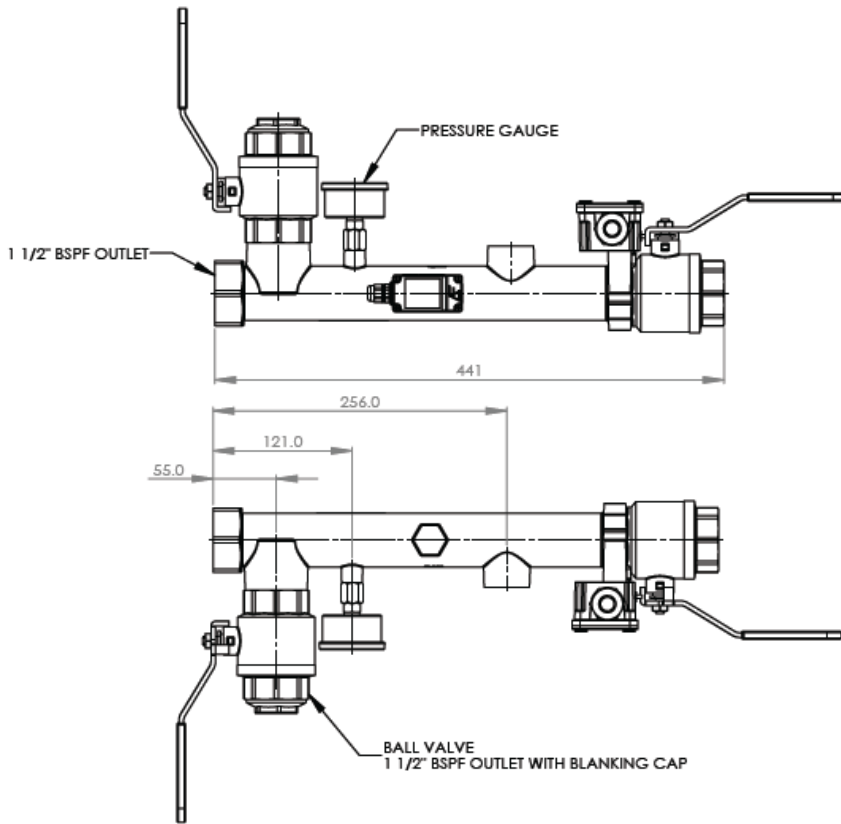

Order Number	Description
AE VS3-A-M	DN40 (1 1/2") Dual Port Residential Valve set kit with Pre-fitted Monitored Ball Valve
AE VS4-A-M	DN50 (2") Dual Port Residential Valve set kit with Pre-fitted Monitored Ball Valve
AE VS3-A-BB-M	DN40 (1 1/2") Dual Port Residential Valve set kit with CPVC on inlet and outlet with Pre-fitted Monitored Ball Valve
AE VS4-A-BB-M	DN50 (2") Dual Port Residential Valve set kit with CPVC on inlet and outlet with Pre-fitted Monitored Ball Valve
AE VS3-A-C-M	DN40 (1 1/2") Dual Port Residential Valve set kit with Single Check Valve with Pre-fitted Monitored Ball Valve
AE VS4-A-C-M	DN50 (2") Dual Port Residential Valve set kit with Single Check Valve with Pre-fitted Monitored Ball Valve

Technical Data	
Pressure Rating (Manifold)	PN16
Medium Temperature	100°C Max
Ambient Temperature	80°C Max
Flow Switch Protection Class	AEL – IP64 Potter – IP54
Switching Current	AEL - Max 1 A Potter – 10 Amp
Switching voltage	Max 250 VAC
Contacts	AEL – SPST Potter – 2 x SPDT

*Many more options available, just ask a member of the team for details

