

Priority Demand Valve 2 1/2" - 4"



Key Features:

- Flow & level switch Input to activate PDV
- Failsafe will close PDV in event of power cut
- Manual reset button to ensure system checked after activation
- If the system fault remains unresolved after manual reset then the PDV will activate again to prevent reset when not safe
- Time delay function to prevent false activation without the need for expensive time delay flow switch
- Internal sounder beacon to alert on activation
- Volt free contact can be used as a fire output with activation solely by signal from the flow switch.

Application Engineering's BS 9251:2021 compliant priority demand valve assembly is for use upon activation of a flow or level switch, whereupon the valve will automatically close the domestic water supply allowing all water to divert to the sprinkler system.

The priority demand valve is available in various sizes and comes with either a solenoid valve (sizes 1/2" - 2") or butterfly valve with an electric actuator (sizes 2 1/2" - 8") along with a 230v Relay box.

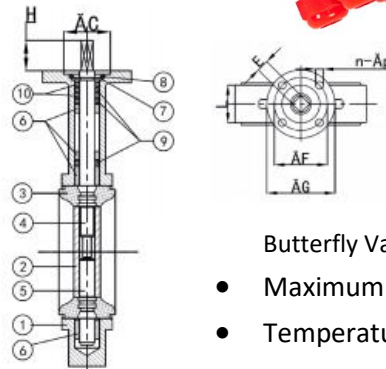
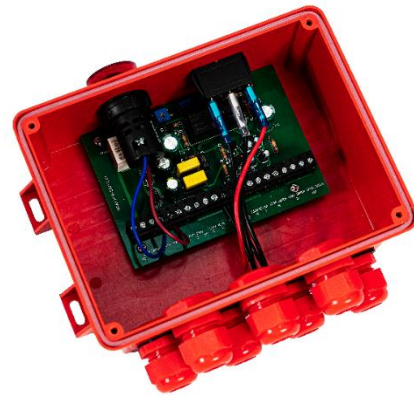

Butterfly Valve Technical data:

- Maximum Pressure 16 Bar Working
- Temperature -10°C to +110°C

N.	Part Name	Material
1	Body	Ductile Iron GGG40
2	Disc	Stainless Steel 316
3	Seat	WRAS EPDM
4	Upper Shaft	Stainless Steel 420
5	Lower Shaft	Stainless Steel 420
6	Bushing	PTFE
7	Split Pin	Spring Steel 65Mn
8	Circlip	Spring Steel 65Mn
9	O-ring	WRAS EPDM
10	Ring	Nylon 6 PA6
11	Lever	DN50-150 Aluminium DN200-300 D
12	Bolt	Stainless Steel 304
1	Body	Ductile Iron GGG40

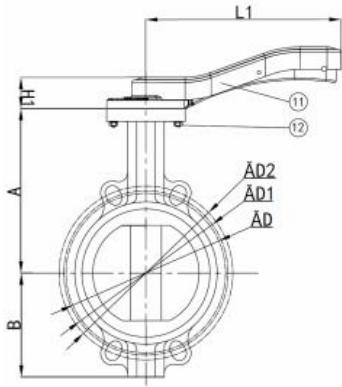

	50	65	80	100	125	150	200	250	300
A	142	154.5	161	180	193	205	250	282	326
B	60	70	85	104	120	135	171	205	248
D	125	145	160	180	210	240	295	350	400
D1	125	145	160	180	210	240	295	350	410
D2	120.7	139.7	152.4	190.5	215.9	241.3	298.5	361.9	431.8

Design Construction

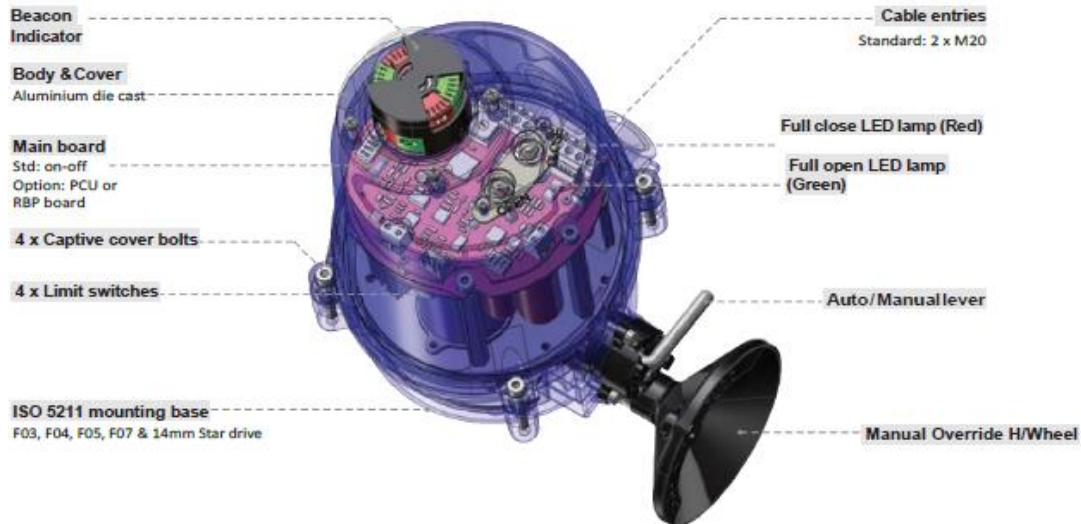

Actuator Specification

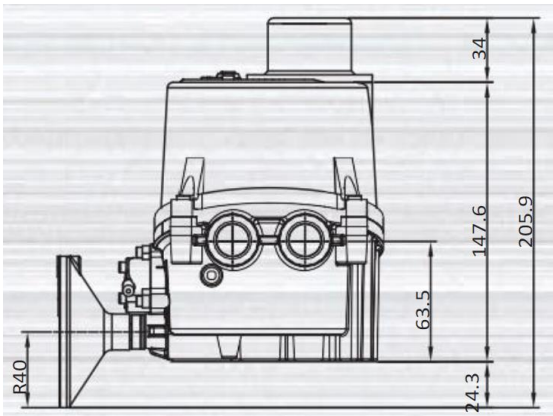

Enclosure	Weatherproof enclosure IP67
Power supply	85 - 265 VAC 1 ph, 50/60 Hz 24 VAC/DC
Duty cycle	S4: 70% (average load of 80% Max. torque) S2: 50% (average load of 80% Max. torque)
Motor	BLDC motor
Limit switch	2 x open/close, SPDT, 250 V ac 10 A rating
Additional limit switches	2 x open/close, SPDT, 250 V ac 10 A rating
Anti-condensation board	2 W
Manual override	Manual Handwheel
Cable entries	Standard: 2 x M20
Movement Angle	320 ± 10° (0 - 330°)
Ambient Temperature	-20 to +80 °C

How to Order

Port Size (G)	Part Number
2 1/2"	AE-PDV21-250
3"	AE-PDV21-300
4"	AE-PDV21-400
5"	AE-PDV21-500
6"	AE-PDV21-600
7"	AE-PDV21-700
8"	AE-PDV21-800

Wiring

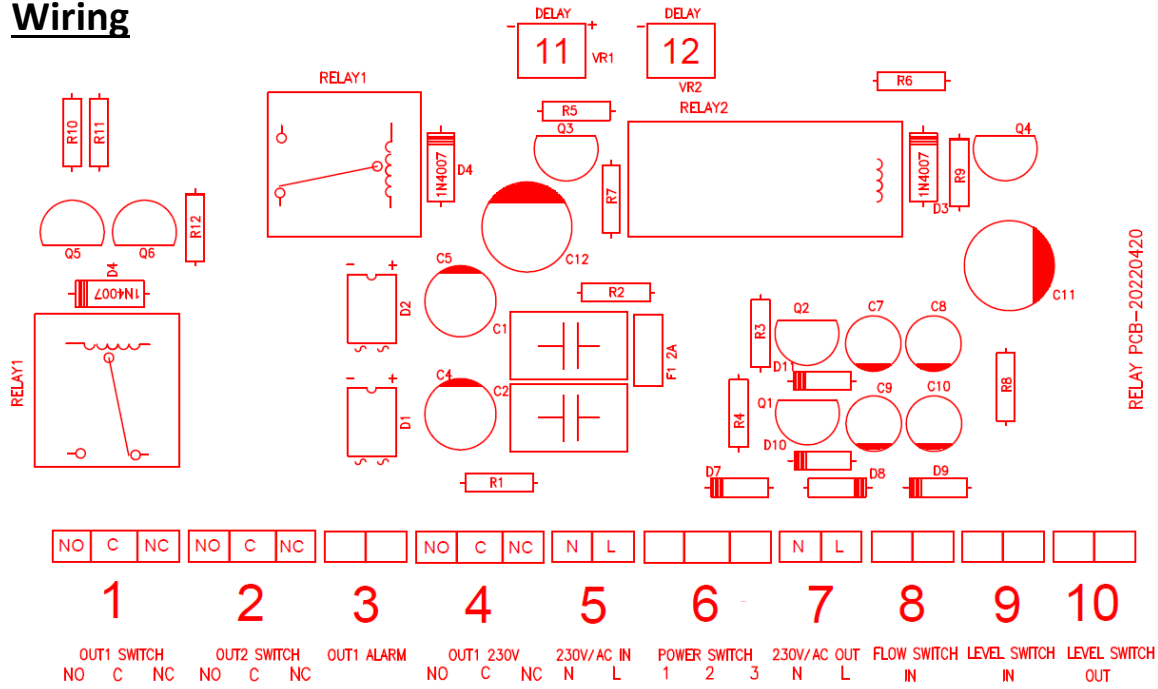

Relay Box Wiring

- | | |
|--|---|
| <ul style="list-style-type: none"> 1 - NO Output on OUT1 SWITCH to input 3 on Actuator 2 - C Output on OUT1 SWITCH to input 4 on Actuator 3 - NC Output on OUT1 SWITCH to input 2 on Actuator 4 - Volt free contact (for external alarm) 5 - Pre-wired Output to sounder beacon 6 - Optional powered output 7 - 230v Mains Power in 8 - Pre-wired output to Reset Button | <ul style="list-style-type: none"> 9 - N Output on 230VAC OUT to input 5 on Actuator 10 - L Output on 230VAC OUT to input 6 on Actuator 11 - Flow Switch Input - Not Polarity Sensitive (NPS) 12 - Level Switch Input (for low level) - NPS 13 - Low Level alarm output -NPS 14 - Adjustable Time Delay 1 15 - Adjustable Time Delay 2 |
|--|---|
- *Turn clockwise to increase time delay, each delay controls a separate relay so both need adjusting

Butterfly Actuator Wiring

- 2 on actuator to N/C in Output 1 of relay box
- 3 on actuator to N/O in Output 1 of relay box
- 4 on actuator to C in Output 1 of relay box
- 5 on actuator to N in Output 7 of relay box
- 6 on actuator to L in Output 7 of relay box

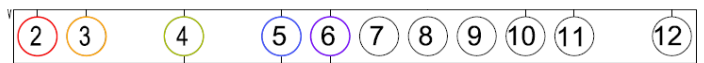

To engage battery backup, ensure jumper is in J4 and position switch to **CLOSE**

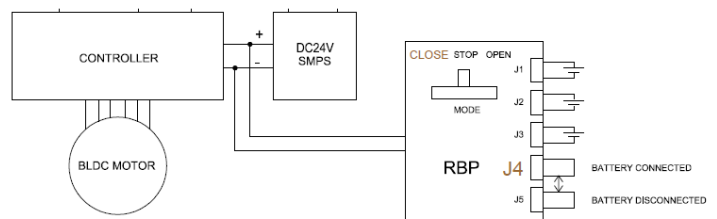

NOTE.
TO PUT BATTERY IN CIRCUIT MOVE JUMPER FROM J5 TO J4
SET FAIL MODE USING THE SELECTOR SWITCH: OPEN, STOP OR CLOSE

BS9251:2021 states that the PDV should have a failsafe so the actuator needs to have the battery backup engaged to ensure activation in the result of a power loss.

Wiring Notes

- The outputs from the relay linking to the actuated butterfly valve do not need any external power, the wires are only to link between the relay box and actuator
- The 'LEVEL SWITCH OUT' is a volt free normally open output switching on activation of the level switch to be used as a low-level alarm. If a low-level alarm not needed then it can just be left unwired
- The FLOW SWITCH & LEVEL SWITCH inputs are volt free normally open inputs, all they are looking for is a closed signal on activation of the switches

Installation Notes

- Once wiring is complete the butterfly valve will be permanently powered open, there is a visual indication on the top of the actuator showing the state of the valve, in the result of a power loss the built-in battery back-up will activate and failsafe closed when the switch inside the actuator is set to close. The valve will then reopen once power is restored and the battery will recharge.
- On activation of either the flow or level switch the sounder beacon will activate and the butterfly valve will close. A manual reset is required to turn off the sounder beacon and reopen the butterfly valve, this is carried out by turning the power switch off and on again. If the fault has not been fixed then the alarm will sound again and another manual reset will be required
- The OUT1 SWITCH is a volt free output that will only activate in the result of a signal from the flow switch and can therefore be used as a fire output. This output will stop alarming once the flow switch stops activating, however, a manual reset is still required to return the PDV to a working state