



MVA/MVS Pressure Switch SPST

The MVA/MVS range has been developed by Applications Engineering Ltd as a rugged general purpose vacuum switch suitable for applications where cost and reliability are leading factors. Available as both adjustable (MVA) and factory set versions (MVS) with SPST electrical contacts.

OPTIONS	
Adjustment Range	2 : 100-900 mbar Or specify set point, e.g. 200F = 200mbar falling
Thread Sizes	G1/4, G1/8, G1/4T, G1/8T, 1/8 NPT, 1/4 NPT (other threads available on request)
Contacts	NO (normally open) or NC (normally closed)
Terminals	SP : Spade terminals ST : Screw terminal (other options on request)
Diaphragm/Piston	N : Nitrile (-15~90°C) V : Viton (-20~110°C) E : EPDM (-15~80°C) H : HNBR (-40~140°C) (Other options available on request)
Body Material	Blank : Brass ZN : Zinc plated steel 316 : 316 grade stainless steel
Options	SG : Degreased for use in oxygen applications For other options please consult Applications Engineering Ltd

SPECIFICATIONS	
Working Voltage	48Vdc Max
Electrical Load	0.5A
Maximum Pressure	20 bar
Mechanical Life	10 ⁶ Operations
Electrical Protection	IP54, Terminals IP00
Contact material	Silver
Contact Holder Material	Nylon 6/6 fv.30

DIMENSIONS

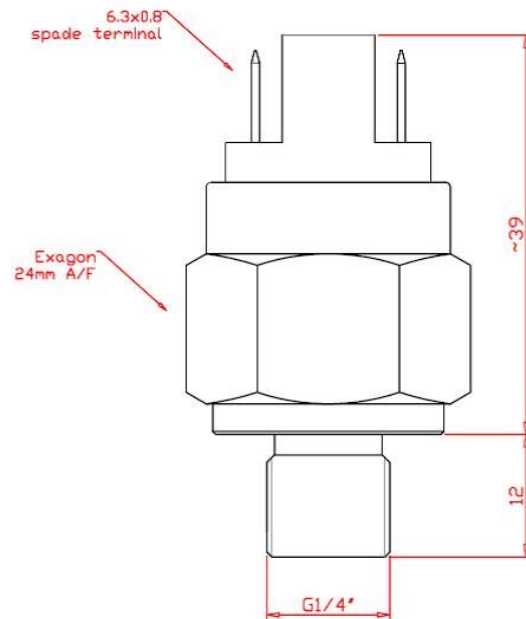

PARTS MATRIX

MVA/MVS	2	G1/4	NO	SP	V	316	-
---------	---	------	----	----	---	-----	---

