

# PS75 – Rugged Cylindrical Pressure Switch

- ▶ Side Mounted DIN Connection
- ▶ Top Mounted Electrical Connection
- ▶ 5 to 6000 psi (0.35 to 414 bar)
- ▶ Wear Disc Design for Longer Life
- ▶ DPDT Models Available

Gems PS75 Series have all metal surfaces for overload stops and deliver reliable operation under extremely high pressure surges. They are designed with a wear disc and cushioning ring for increased life. The switches use a piston/diaphragm design, which combine the high proof pressure of piston technology with the sensitivity of a diaphragm design. They can be field or factory adjusted.

## Specifications

<b>Switch</b>	SPST; SPDT; DPST; DPDT
<b>Repeatability</b>	See Table 1
<b>Wetted Parts</b>	
<b>Diaphragm</b>	Nitrile (optional Viton®, Neoprene or EPDM)
<b>Fitting</b>	Zinc-Plated Steel (optional 316 Stainless Steel)
<b>Housing</b>	Brass or Zinc-Plated Steel (optional 316 Stainless Steel)
<b>Electrical Termination</b>	DIN 43650A IP65; Conduit with Flying Leads IP65; Flying Leads IP65
<b>Proof Pressure</b>	7500 psi (517 bar) except range 10: 500 psi (35 bar)
<b>Burst Pressure</b>	9000 psi (600 bar)
<b>Approvals</b>	CE, UL Approved units available
<b>Weight, Approximate</b>	Steel: 0.6 lbs. (0.27 kg)

## Recommended Operating Temperature Limits

Diaphragm Material	Circuit Codes	
	-A, -B, -C	-AA, -BB, -CC (or -A, -B, -C with -RD option)
<b>Nitrile (Std)</b>	15°F to 185°F (-9°C to +85°C)	15°F to 250°F (-9°C to +121°C)
<b>Viton®</b>	0°F to 185°F (-18°C to +85°C)	0°F to 250°F (-18°C to +121°C)
<b>EPDM</b>	-10°F to +185°F (-23°C to +85°C)	-10°F to +250°F (-23°C to +121°C)
<b>Neoprene</b>	-10°F to +185°F (-23°C to +85°C)	-10°F to +250°F (-23°C to +121°C)

Note: Switches may function below the cold temperature limit but the set points and deadband will increase. Consult factory for details.

## Electrical Switch Ratings

Circuit Code	AC	DC
<b>-A, -B, -C<sup>1</sup></b>	5 amps @ 125/250 Volts	5 amps resistive, 3 amps inductive @ 28 Volts
<b>-A, -B, -C<sup>2</sup></b>	1 amp @ 125 Volts	1 amp resistive, 0.5 amp inductive @ 28 Volts
<b>-AA, -BB, -CC<sup>1</sup></b>	2 switches rated 5 amps @ 125/250 Volts	2 switches rated 5 amps resistive, 3 amps inductive @ 28 Volts
<b>-AA, -BB, -CC<sup>2</sup></b>	2 switches rated 1 amp @ 125/250 Volts	2 switches rated 1 amp resistive, 0.5 amp inductive @ 28 Volts

Notes:

- Without Gold Contacts Option (-G).
- With Gold Contacts Option (-G).

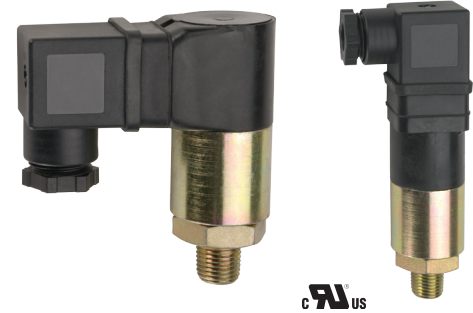

## Dimensions

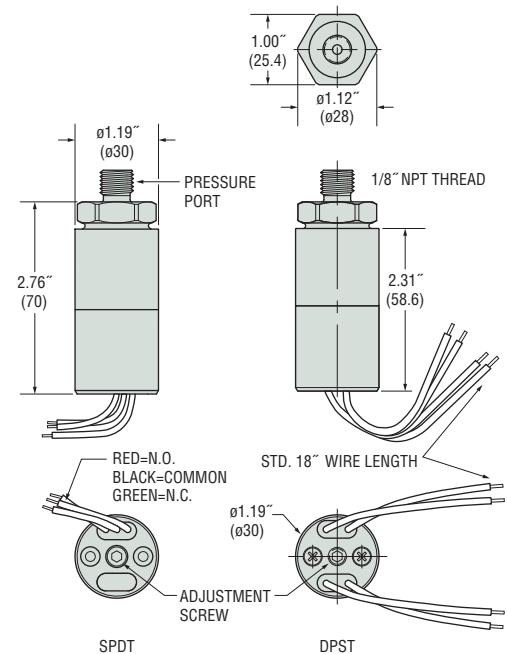
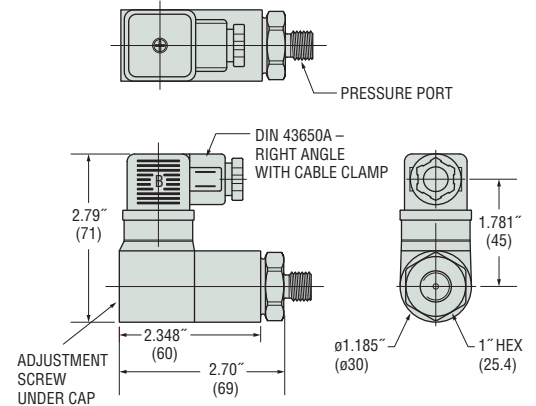

**APPLICATIONS  
ENGINEERING LTD**

16 HORSTED SQUARE, BELLBROOK INDUSTRIAL ESTATE,  
UCKFIELD, EAST SUSSEX, TN22 1QG, UK

## How To Order

Use the **Bold** characters from the chart below to construct a product code. Please reference Notes.

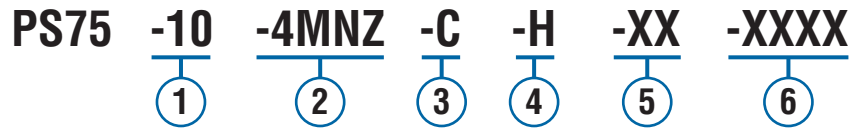

### 1 Pressure Range Code

Insert Pressure Range Code from Table 1, below.

### 2 Pressure Fitting<sup>1</sup>

12L14 Zinc-Plated Steel

- 2MNZ = 1/8" NPTM
- 4MNZ = 1/4" NPTM
- 4FNZ = 1/4" NPTF
- 4MGZ = 1/4" BSPM (G type)
- 4FGZ = 1/4" BSPF (G type)
- 4MSZ = 7/16"-20 SAE Male
- 6MSZ = 9/16"-18 SAE Male
- 4SSZ = 7/16"-20 SAE Male Swivel

316 Stainless Steel

- 4MNS = 1/4" NPTM
- 4MGS = 1/4" BSPM (G type)
- 4FGS = 1/4" BSPF (G type)
- 6MSS = 9/16"-18 SAE Male

### 3 Circuit

- A = SPST/N.O.
- B = SPST/N.C.
- C = SPDT
- AA = DPST/N.O.<sup>2</sup>
- BB = DPST/N.C.<sup>2</sup>
- CC = DPDT<sup>2</sup>

### 4 Electrical Termination

- FLXX = Flying Leads<sup>3</sup>
- ELXX = 1/2" NPT Male Conduit w/Flying Leads<sup>4</sup>
- H = DIN 43650A Male Half Only<sup>5</sup>
- HR = Right Angle DIN 43650A Male Half Only<sup>5</sup>
- HC = DIN 43650A 9mm Cable Clamp<sup>5</sup>
- HCR = Right Angle DIN 43650A 9mm Cable Clamp<sup>5</sup>
- HN = DIN 43650A with 1/2" Female NPT Conduit<sup>5</sup>
- HNR = Right Angle DIN 43650A with 1/2" Female NPT Conduit<sup>5</sup>

### 5 Options

- V = Viton<sup>®</sup> Diaphragm
- N = Neoprene Diaphragm
- E = EPDM Diaphragm
- G = Gold Contacts  
(for loads less than 12 mA @ 12 VDC)
- RD = Reduced Differential (25% reduction typical)
- OXY = Oxygen Cleaned<sup>6</sup>
- R = Restrictor (low damping coefficient) Brass
- SR = Spiral Restrictor (high damping coefficient)  
300 Series Stainless Steel<sup>7</sup>
- WF = Weather Pack Connector, Female
- WM = Weather Pack Connector, Male
- DE = Deutsch Connector, Male, DT04 Series

### 6 Fixed Set Point (optional)

- A. Specify set point -FS (in PSI or BAR, see example)<sup>8</sup>
- B. Set Point Actuation
- R on Rising Pressure
- F on Falling Pressure
- Example: -FS1BARF for 1 BAR Falling
- or -FS20PSIR for 20 PSI Rising

Notes:

1. Manifold mounts available. Consult factory.
2. Requires -FL or -EL electrical termination.
3. 18" is standard. Specify lead length in inches (max. 48"). e.g. -FL18 or -FL30.
4. 18" is standard. Specify lead length in inches (max. 48"). e.g. -EL18 or -EL30.
5. DIN connectors require -C SPDT circuit.
6. Requires stainless steel pressure fitting.
7. -SR will result in wider deadbands and slower response times.
8. Set Point must be within Pressure Range selected in Step 1.

Table 1 — Pressure Range Codes

For Circuit Codes -A, -B and -C

Pressure Range Code	Pressure Range	Repeatability*	Average Deadband**
<b>10</b>	5-25 psi (0.35-1.7 bar)	±1.0 psi (0.07 bar) +2% of setting	3 psi (0.21 bar) +5% of setting
<b>20</b>	15-75 psi (1.0-5.2 bar)	±2.5 psi (0.17 bar) +2% of setting	5 psig (0.34 bar) +10% of setting
<b>30</b>	50-150 psi (3.5-10.3 bar)	±6 psi (0.41 bar) +2% of setting	15 psig (1.03 bar) +13% of setting
<b>40</b>	150-650 psi (10.3-44.8 bar)	±15 psi (1.03 bar) +2% of setting	25 psi (1.72 bar) +14% of setting
<b>50</b>	500-1750 psi (34.5-121 bar)	±25 psi (1.72 bar) +2% of setting	55 psi (3.79 bar) +15% of setting
<b>60</b>	1000-3500 psi (69-241 bar)	±45 psi (3.10 bar) +3% of setting	100 psi (6.89 bar) +16% of setting
<b>70</b>	2500-6000 psi (172-414 bar)	±80 psi (5.51 bar) +4% of setting	200 psi (13.8 bar) +17% of setting

For Circuit Codes -AA, -BB and -CC\*\*\*

Pressure Range Code	Pressure Range	Repeatability*	Average Deadband**
<b>10</b>	5-25 psi (0.35-1.7 bar)	±1.5 psi (0.10 bar) +3% of setting	2 psi (0.14 bar) +5% of setting
<b>20</b>	15-75 psi (1.0-5.2 bar)	±3.5 psi (0.24 bar) +3% of setting	4 psig (0.28 bar) +8% of setting
<b>30</b>	50-150 psi (3.5-10.3 bar)	±9 psi (0.62 bar) +3% of setting	13 psig (0.90 bar) +10% of setting
<b>40</b>	150-650 psi (10.3-44.8 bar)	±22 psi (1.51 bar) +3% of setting	21 psi (1.45 bar) +11% of setting
<b>50</b>	500-1750 psi (34.5-121 bar)	±35 psi (2.41 bar) +3% of setting	45 psi (3.10 bar) +12% of setting
<b>60</b>	1000-3500 psi (69-241 bar)	±60 psi (4.14 bar) +4% of setting	80 psi (5.52 bar) +13% of setting
<b>70</b>	2500-6000 psi (172-414 bar)	±100 psi (6.89 bar) +5% of setting	160 psi (11.0 bar) +14% of setting

\* Repeatability and set point of units may change due to the effects of temperature.

\*\* In certain applications deadband can be tailored and controlled to customer specifications. Consult factory for details.

\*\*\* Operation of both switches in most cases will not be simultaneous but will occur within the specifications listed. Deadband figures already reflect the improvement from the -RD option which is automatically included in the -AA, -BB and -CC circuits.