

B-Cryo Series

- ▶ MOPD: 900 PSI
- ▶ C_v Range: 0.045 to 0.440
- ▶ 9 Watts

The B-Cryo Series is a 2-way miniature Cryogenic valve designed and built for service down to -320°F (-196°C) in applications needing a C_v between 0.045 and 0.440. Depending on your temperature requirements, the B-Cryo Series can be configured for liquid nitrogen (LN2), liquid carbon dioxide (LCO2), and other extreme temperature media. PTFE coated plungers, 316 Stainless Steel guide tubes and plunger springs, encapsulated coils, and PTFE or Rulon® seat seals produce a truly robust Cryogenic valve for applications requiring high cycle life and media temperature control.



Typical Applications

- Environmental Chambers
- Food Processing
- Laser Surgical Equipment
- Semiconductor Manufacturing

Dimensions

LN2-Liquid Nitrogen

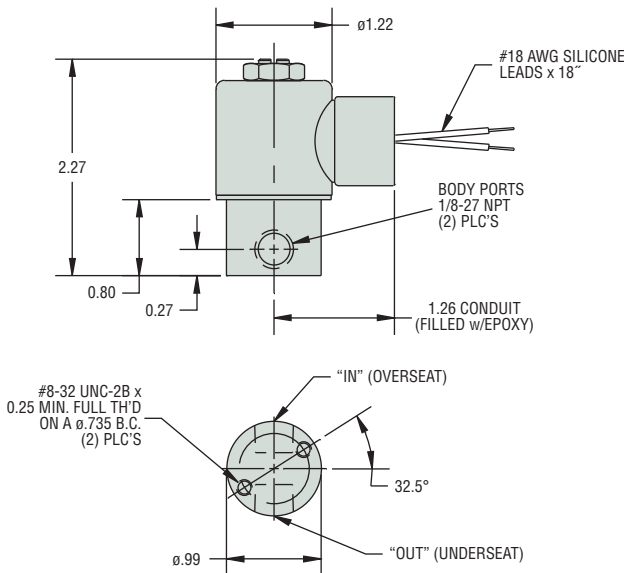

LCO2-Liquid Carbon Dioxide

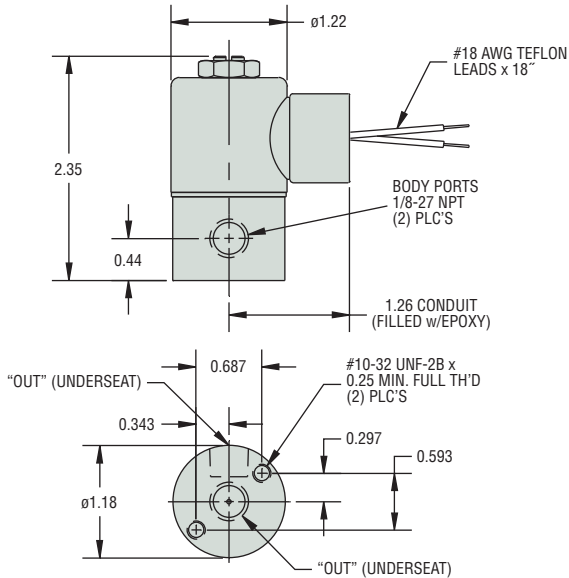

How To Order

Use the **Bold** characters from the choices listed on the following page to construct a product code.

B2062 - LN2 - **LB - 120/50/60VAC**

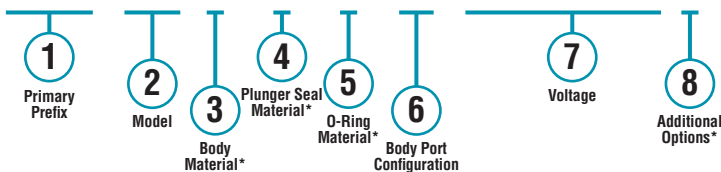

* Blank entry indicates a "Standard" selection (430F Stainless Steel, Rulon® and Variseal®, in this case).

Example:

B2062-LN2-LB-120/50/60VAC

2-Way N.C. Liquid Nitrogen Class-H Encapsulated Coil with lead-wires, conduit filled housing solenoid valve, with 430F stainless steel body, Rulon® plunger seal, Variseal® o-ring, 1/4-18 NPT female thread, operating at 120/50/60 Volt AC.

SOLENOID VALVES

Part Prefix Table ①

		① Primary Prefix			
Orifice Body	MOPD (psig)	C _v Body	Class H, Encapsulated Coils		
			Lead Wires—Filled Conduit Housing	Lead Wires—Unfilled Conduit Housing	Lead Wires— Grommet Housing
3/64	900	0.045	B2060	B2020	B2010
1/16	405	0.075	B2061	B2021	B2011
5/64	270	0.105	B2062	B2022	B2012
3/32	160	0.160	B2063	B2023	B2013
7/64	110	0.190	B2064	B2024	B2014
1/8	80	0.255	B2065	B2025	B2015
5/32	65	0.365	B2066	B2026	B2016
3/16	30	0.440	B2067	B2027	B2017

② Model

- LN2 = Liquid Nitrogen model
- LCO2 = Liquid Carbon Dioxide model

③ Body Material

LN2 Only

(blank) = 430F Stainless Steel*

LCO2 Only

(blank) = 303 Stainless Steel*

BB = Brass

SB = 304 Stainless Steel

SB5 = 316 Stainless Steel

④ Plunger Seal Material

LN2 Only

(blank) = Rulon®*

LCO2 Only

(blank) = PTFE*

MQ = Silicone (consult factory)

⑤ O-Ring Material

LN2 Only

(blank) = Variseal® (PTFE material with internal spring)*

TO = PTFE (consult factory)

LCO2 Only

(blank) = Variseal® (PTFE material with internal spring)*

TO = PTFE (consult factory)

⑥ Body Port Configuration

LN2 Only

(blank) = 1/8-27 NPT female thread*

LB = 1/4-18 NPT female thread

LT = 1/8-28 BSPT female thread

LU = 1/4-19 BSPT female thread

BI = Bottom over-seat port, female thread (max. orifice = 1/8")

BO = Bottom under-seat port, female thread

RL = 90° porting - left hand

RR = 90° porting - right hand

LCO2 Only

(blank) = 1/8-27 NPT, bottom under-seat port, female thread*

LB = 1/4-18 NPT female thread (in-line porting only)

LT = 1/8-28 BSPT female thread

LU = 1/4-19 BSPT female thread (in-line porting only)

BOM = Bottom under-seat port, male thread

(max. orifice = 1/8", brass body only)

IL = Inline porting, 180° apart

⑦ Voltage

LN2 Only

___ VDC = DC (specify voltage)

___ VAC = AC Rectified (specify voltage)

LCO2 Only

___ VDC = DC (specify voltage)

___ VAC = AC Rectified (specify voltage)

⑧ Additional Options

LN2 Only

(blank) = Chamfered and PTFE coated plunger*

(blank) = 316 Stainless Steel 1-piece guide assembly*

(blank) = 316 Stainless Steel spring*

LCO2 Only

(blank) = Chamfered and PTFE coated plunger*

(blank) = 316 Stainless Steel 1-piece guide assembly*

(blank) = 316 Stainless Steel spring*

* Standard selection; will be used unless otherwise specified. Standard selections are not referenced in final part number.