

692

Differential pressure transmitter

0 to 25 bar

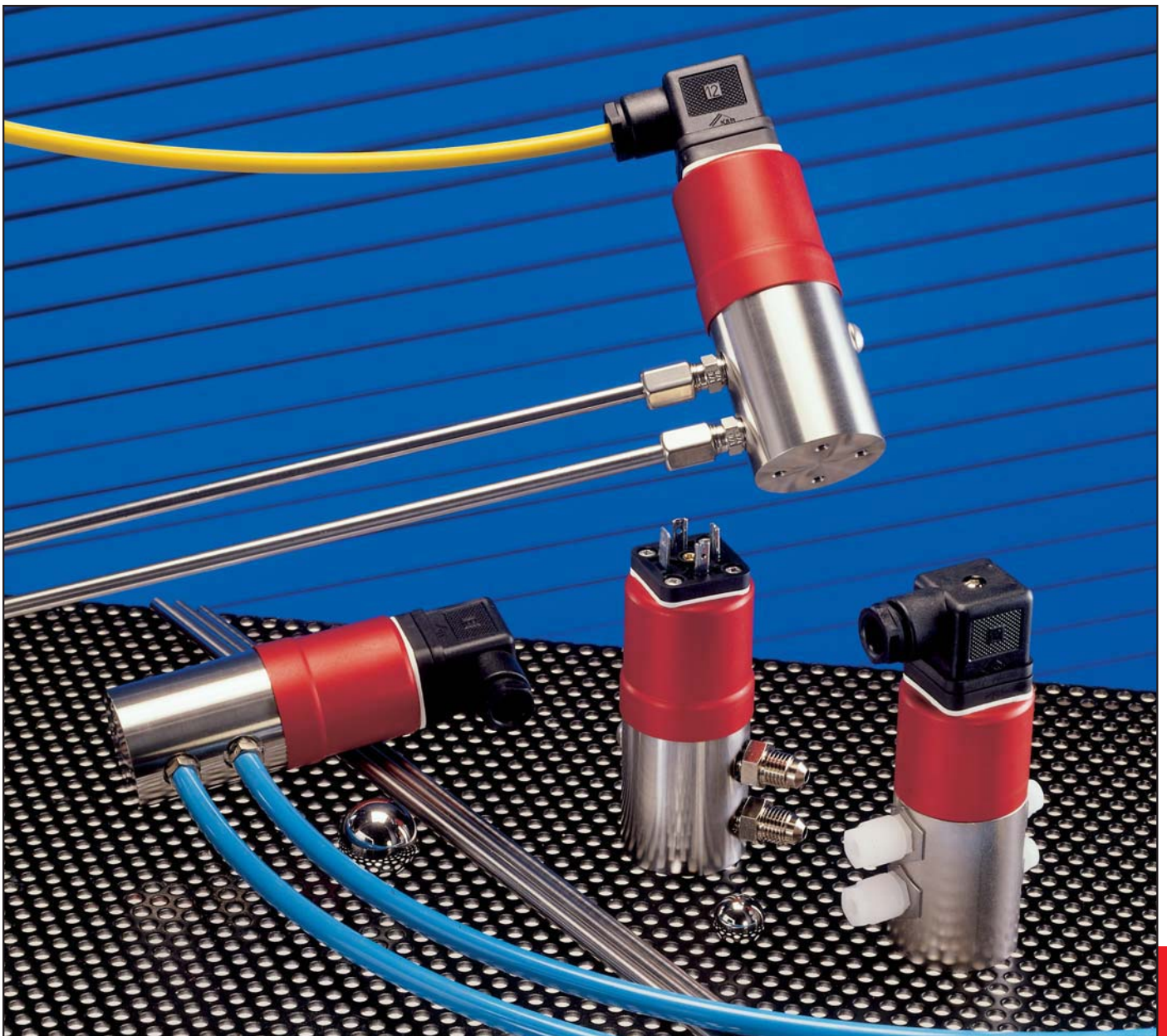

EDITION 4/2005

HUBA-REGISTERED TRADE MARK



Technical overview

The differential pressure transmitter of type series 692 with proven, unique ceramic technology, features calibrated and amplified sensor signals which are available as standardised voltage or current outputs.

Various application-specific pressure and electrical connections and housing materials suitable for different media can be provided.

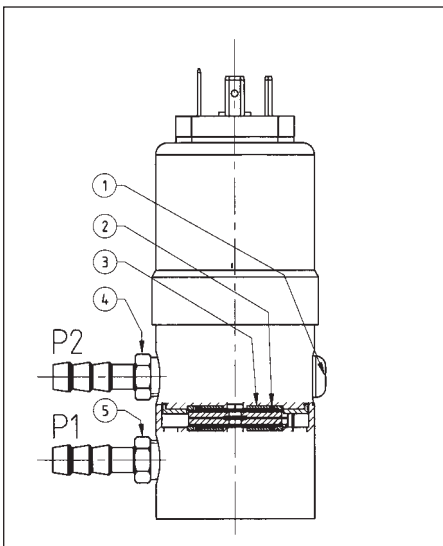

Legend to cross-section drawing

- 1 Fixing screw (do not loosen)
- 2 Seals
- 3 Ceramic element
- 4 P2 lower pressure, higher vacuum
- 5 P1 higher pressure, lower vacuum

The distinct advantages

- Very low temperature sensitivity
- High resistance to extreme temperatures
- No mechanical ageing
- No mechanical creepage
- Modular system and choice of materials to suit individual applications

Pressure ranges

Relative pressure, see order code selection table

Overload

see order code selection table

System pressure

(P1 and P2 simultaneously)
25 bar to pressure range 6 bar
50 bar on pressure range 10/16/25 bar

Rupture pressure

1.5 x system pressure

Accuracy (linear signals)

Total of linearity, hysteresis and repeatability
< +/- 0.5 % fs at 2 x nominal pressure
< +/- 0.8 % fs at 3 x nominal pressure
< +/- 1.3 % fs at 5 x nominal pressure
Zero point residual voltage
< 50 mV at 2 x nominal pressure
< 75 mV at 3 x nominal pressure
< 125 mV at 5 x nominal pressure

Materials in contact with the medium

Ceramic/Stainless steel 1.4305, PVDF

Sealing material:

option FPM, EPDM, NBR, MVQ
acc. to order code selection table

Temperature influences (linear signals)

Medium and ambient temperature
-15 °C to +80 °C
TC zero point see order code selection table
TC sensitivity (% fs/K)
< +/- 0.015 at 2 x nominal pressure
< +/- 0.022 at 3 x nominal pressure
< +/- 0.037 at 5 x nominal pressure

Load cycle

< 50 Hz

Dynamic response

Suitable for static and dynamic measurements.
Response time: < 5 ms

Weight

approx. 430 grams

Installation arrangement

Unrestricted

Signal

0 – 5 V

0 – 10 V

4 – 20 mA

Power supply

11 – 33 VDC
24 VAC +/- 15%
3-wire cable
18 – 33 VDC
24 VAC +/- 15%
3-wire cable
11 – 33 VDC
2-wire cable

Short circuit-proof and protected against polarity reversal. Each connection against other with max. +/- supply voltage

Load

0 – 5 V > 10 k Ohm
0 – 10 V > 10 k Ohm
4 – 20 mA $\leq \frac{\text{supply voltage} - 11 \text{ V}}{0.02 \text{ A}}$ [Ohm]

Current consumption

At maximum signal output:
0 – 5 V < 5 mA
0 – 10 V < 5 mA
4 – 20 mA < 25 mA

Electrical connections / Protection standard

Cable 1.5 meters, IP 65, with cable gland (threaded)
Rount plug connector DIN 41524, 3-pole, IP 65
Connector DIN EN 175301-803-A, IP 65

Calibration

Adjustable versions
(zero point/slope approx. +/- 10%)

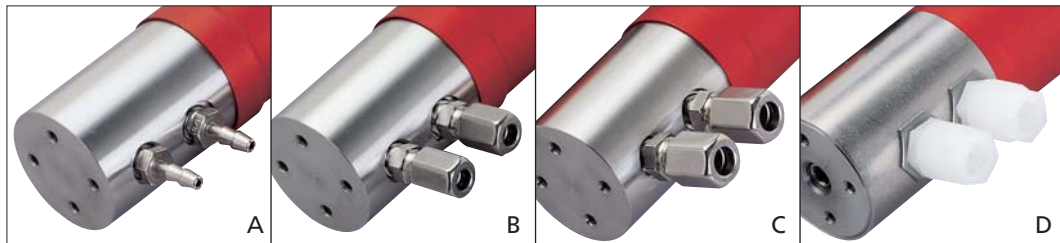

Versions

- A – Pressure Tube Tip for pipe
Ø 4 mm
- B – Screw fitting for pipe
Ø 6 mm
- C – Screw fitting for pipe
Ø 8 mm
- D – Screw fitting PVDF for pipe
Ø 8 mm

Order code selection table

692. 9 X X X X X X X X

Pressure ranges ¹	Overload on one side		TC0 (fs/K)															
	P 1	P 2																
0 ... + 0.1	max. 0.6 bar	0.6 bar	< 0.12 %			0	0											
0 ... + 0.2	max. 1.2 bar	1.2 bar	< 0.12 %			0	2											
0 ... + 0.2	max. 0.6 bar	0.6 bar	< 0.06 %			4	0											
0 ... + 0.25	max. 1.2 bar	1.2 bar	< 0.1 %			0	3											
0 ... + 0.25	max. 0.6 bar	0.6 bar	< 0.05 %			4	1											
0 ... + 0.3	max. 0.6 bar	0.6 bar	< 0.04 %			0	1											
0 ... + 0.4	max. 1.2 bar	1.2 bar	< 0.06 %			0	4											
0 ... + 0.4	max. 2 bar	2 bar	< 0.1 %			0	5											
0 ... + 0.5	max. 1.2 bar	1.2 bar	< 0.05 %			0	6											
0 ... + 0.5	max. 3 bar	3 bar	< 0.12 %			0	7											
0 ... + 0.6	max. 1.2 bar	1.2 bar	< 0.04 %			0	8											
0 ... + 0.6	max. 3 bar	3 bar	< 0.1 %			0	9											
0 ... + 1	max. 2 bar	2 bar	< 0.04 %			1	1											
0 ... + 1	max. 5 bar	5 bar	< 0.1 %			1	2											
0 ... + 1.6	max. 3.2 bar	3.2 bar	< 0.04 %			1	3											
0 ... + 1.6	max. 12 bar	12 bar	< 0.15 %			1	4											
0 ... + 2.5	max. 5 bar	5 bar	< 0.04 %			1	5											
0 ... + 2.5	max. 12 bar	12 bar	< 0.1 %			1	6											
0 ... + 4	max. 8 bar	8 bar	< 0.04 %			1	7											
0 ... + 4	max. 12 bar	12 bar	< 0.06 %			1	8											
0 ... + 6	max. 12 bar	12 bar	< 0.04 %			1	9											
0 ... +10	max. 20 bar	12 bar	< 0.04 %			3	0											
0 ... +16	max. 32 bar	12 bar	< 0.04 %			3	1											
0 ... +25	max. 50 bar	12 bar	< 0.04 %			3	2											
▲ Full scale signal at these pressures																		
Sealing materials	FPM	Fluoro-elastomer								0								
	EPDM	Ethylene propylene								1								
	NBR	Butadiene Acrylonitrile								2								
	MVQ	Silicone polymer								3								
Calibration	factory calibrated									0								
	factory calibrated, with adjustable zero point and slope									1								
Outputs and power supply	0 – 5 V	11.0 – 33.0 VDC/24 VAC +/- 15%	3-wire cable							0								
	0 – 10 V	18.0 – 33.0 VDC/24 VAC +/- 15%	3-wire cable							1								
	4 – 20 mA	11.0 – 33.0 VDC	2-wire cable							7								
Electrical connections ²	Cable 1.5 m, Pg 7		IP 65															0
	Connector	DIN EN 175301-803-A	IP 65															1
	Round plug connector	DIN 41524 3-pole	IP 65															3
Pressure connections	without connections	1/8-27 NPT / PVDF G 1/8	only adjustable version															0
	Pressure-tube tip	CuZn vni	for tube Ø 4 mm															1
	Pressure-tube tip	CuZn vni	for tube Ø 6 mm															2
	Pressure-tube tip	PVDF	for tube Ø 6 mm															3
	Screw fitting	CuZn vni	for pipe Ø 6 mm															4
	Screw fitting	Inox 1.4305	for pipe Ø 6 mm															5
	Screw fitting	CuZn vni	for pipe Ø 8 mm															6
	Screw fitting	Inox 1.4305	for pipe Ø 8 mm															7
	Screw fitting	PVDF	for pipe Ø 6 mm															8
	Screw fitting	PVDF	for pipe Ø 8 mm															9
	Outside thread	7/16-20 UNF (CuZn vni)																A
	Adapter inside	G 1/8 Inox	for pipe Ø 6 mm															B
	Adapter outside	G 1/8 with union nut (CuZn)	for pipe Ø 6 mm															C
Case in contact with medium	Stainless steel																	1
	PVDF	all ranges up to 6 bar max., overload and system pressure max. 12 bar																2
	Stainless steel with pressure tip orifice																	4
	Stainless steel, free of oil and grease (only seal FPM, not compound-filled)																	5
	Stainless steel with pressure tip orifice free of oil and grease (only seal FPM, not compound-filled)																	6

Accessories

Female connector	with seal (IP 65 when installed and screwed)	DIN EN 175301-803-A	1	0	3	5	1	0										
Round plug connector	(coupling socket)	DIN 41524 (IP 65)	1	0	3	5	2	4										
Mounting bracket			1	0	1	9	9	9										
Test certificate			1	0	4	5	5	1										

¹ Other pressure ranges on request
² Without female connector

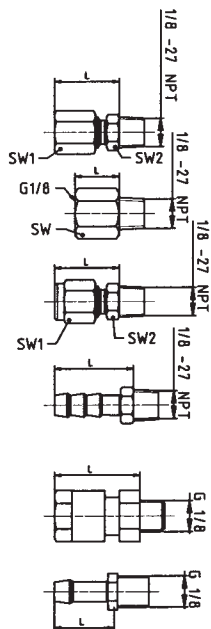
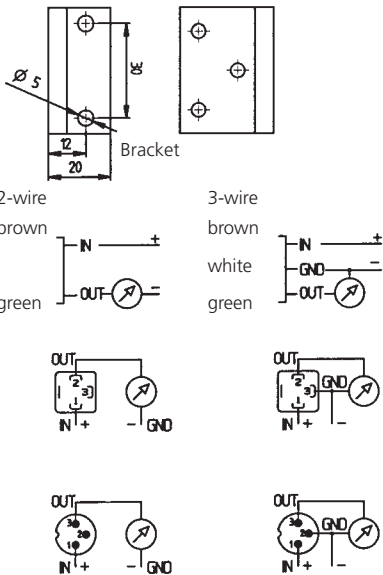
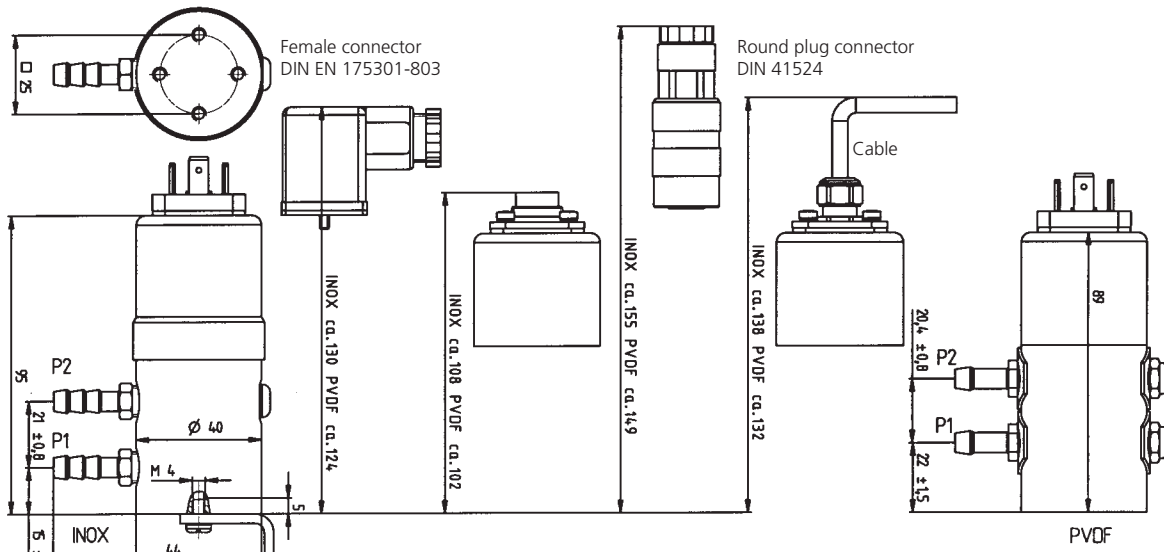

		measure X		
Inox	screw fitting for pipe on the outside Ø 6	SW1 = 10 SW2 = 12	L = ~ 20.5	L = ~ 61.5
	screw fitting for pipe on the outside Ø 8	SW1 = 12 SW2 = 14	L = ~ 22.5	L = ~ 63.5
Inox	adapter G1/8 inside thread	SW = 14	L = ~ 14	L = ~ 55
CuZn	screw fitting for pipe on the outside Ø 6	SW1 = 10 SW2 = 12	L = ~ 20.5	L = ~ 61.5
	screw fitting for pipe on the outside Ø 8	SW1 = 12 SW2 = 14	L = ~ 22.5	L = ~ 63.5
CuZn	pressure tube for tube Ø 4	SW = 10	L = 20	L = ~ 61
Inox	pressure tube for tube Ø 6	SW = 10	L = 25	L = ~ 66
PVDF	pressure fitting for pipe on the outside Ø 6	SW = 12	L = ~ 21.5	L = ~ 62.5
	pressure fitting for pipe on the outside Ø 8	SW = 14	L = ~ 24.7	L = ~ 65.7
PVDF	pressure tube for tube Ø 6	SW = 10	L = 20	L = ~ 63

Electromagnetic compatibility:

CE conformity (EMC) by application of harmonized standards: Interference stability EN 61000-6-2 and EN 61000-6-3

Interference stability	Test standard	Effect	
Electrostatic discharge (ESD)	EN 61000-4-2	8 kV air, 4 kV contact	no effect
High-frequency electromagnetic radiation (HF)	EN 61000-4-3	10 V/m, 80 ... 1000 Mz	no effect
Conducted HF interference	EN 61000-4-6	10 V, 0.15 ... 80 MHz	no effect
Fast transients (burst)	EN 61000-4-4	2 kV	no effect
Surge	EN 61000-4-5	max. tolerable cable length 10 m	no test
Magnetic fields	EN 61000-4-8	30 A/m, 50 Hz	no effect
Interference emit	Test standard	Effect	
Conducted interference	EN 55022 (CISPR 22)	0.15... 30 MHz	no emission
Radiation from housing	30...1000 MHz, 10 m		No emission