

Pressure transmitter for refrigeration technology

Relative $-1 \dots 160$ bar

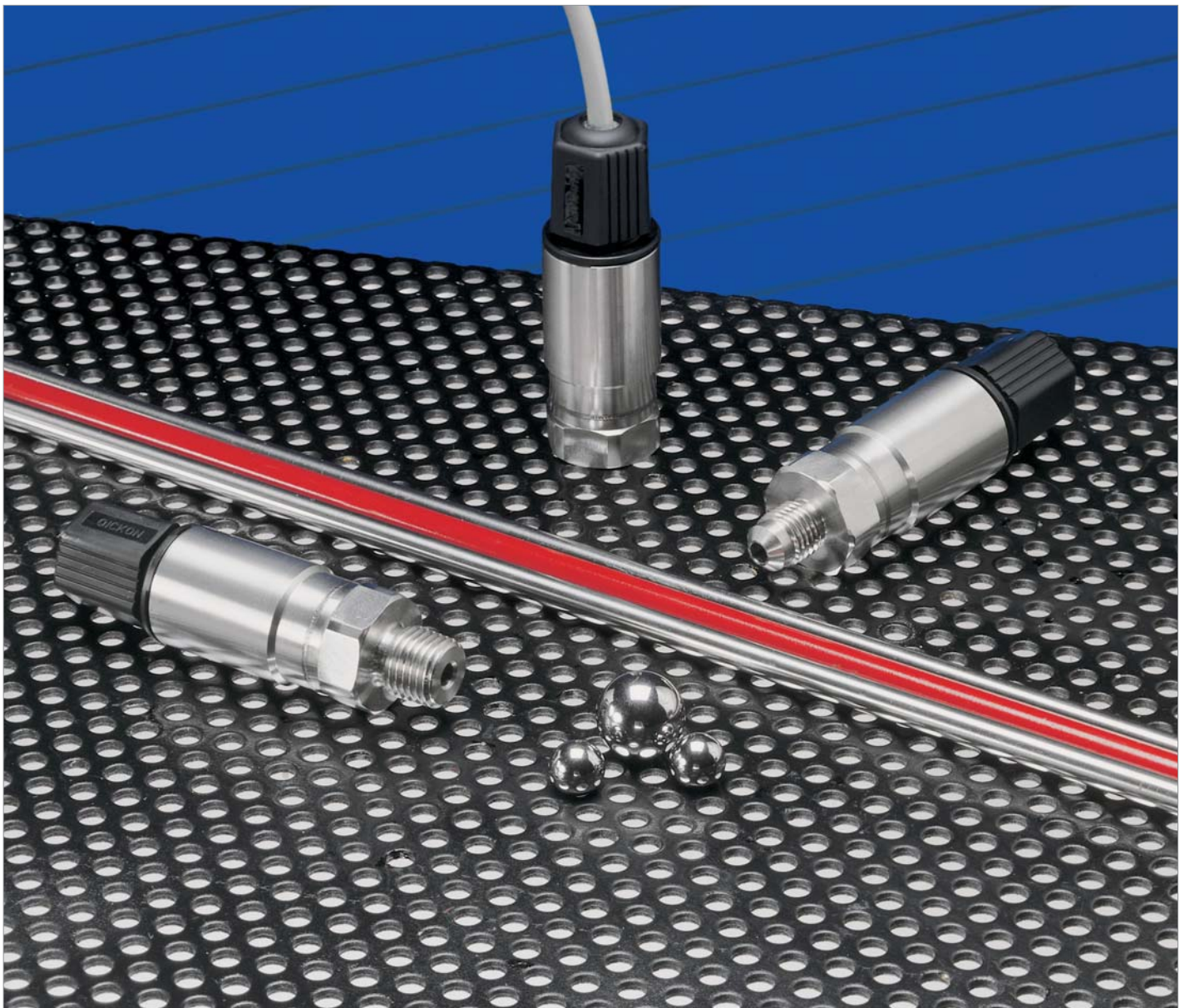

Technical overview

These compact OEM pressure transmitters type 510 have been developed for applications in the industrial refrigeration technology. The special sensor is based on thick-film technology, developed by Huba Control, which utilises a special grade of steel welded to the pressure sensor. This means that the 510 can be used for all gases and media in refrigeration, including ammoniac. Highest requirements concerning EMC and accuracy for all temperature ranges can be met in combination with the unique integrated electronic design.

Suitable from small series to high quantity applications with best price to performance ratio.

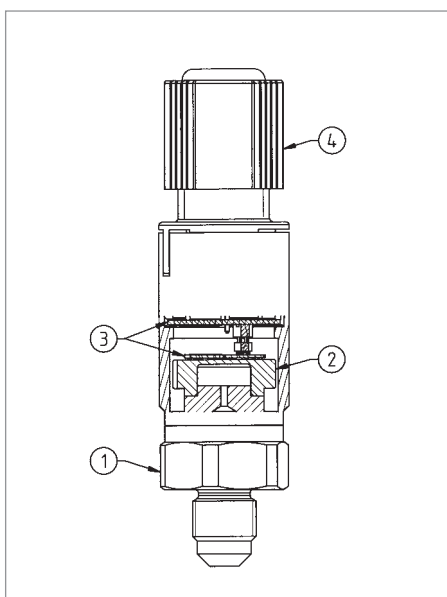

Legend to cross-section drawing

- 1 Connection fitting
- 2 Steel cell welded
- 3 Electronic with EMC-protection
- 4 Electrical connection (example Quickon)

The distinct advantages

- Compact, rugged construction for highest operational reliability
- Protection IP 67 standard
- Welded without sealing parts, no elastomer-sealings
- Negligible temperature influence on accuracy
- Excellent EMC-capacity
- Saving time by quick cable mounting by the customer with Quickon-System

Pressure ranges

Relative pressure
(differential measurement of pressure relative to ambient pressure)

See order code selection table

Overload

3.0 x full scale

Rupture pressure

6.0 x full scale

Accuracy

Total of linearity, hysteresis and repeatability < +/- 0.5% fs

Adjustment accuracy zero point and full scale < +/- 0.5% fs

Housing material

Casing stainless steel 1.4305 (AISI 303)

Materials in contact with the medium

Connection fitting: Stainless steel 1.4305

Steel cell: Stainless steel

Application temperature

Medium temperature - 40 ... + 150 °C

Ambient temperature max. 85 °C

Temperature influences

TC zero point < ± 0.03% fs

TC sensitivity < ± 0.015% fs

Temperature range - 40 ... + 125 °C

Dynamic response

Suitable for static and dynamic measurements.

Response time: < 2 ms, 1 ms typ.

Pressure connections

see order code selection table

Weight

Version inside thread approx. 88 g

Version outside thread approx. 98 g

Installation arrangement

unrestricted

Outputs and power supply

See order code selection table. Short circuit-proof and protected against polarity reversal.

Each connection against other with max. +/- supply voltage

Electric strength 500 VDC

Load

0 ... 5 V > 10 k Ohm/100 nF

1 ... 6 V > 10 k Ohm/100 nF

1 ... 10 V > 10 k Ohm/100 nF

4 ... 20 mA ≤ $\frac{\text{Supply voltage} - 8 \text{ V}}{0.02 \text{ A}}$ [Ohm]

Ratiometric > 10 k Ohm/100 nF

Current consumption

With max. signal output:

0 ... 5 V < 5 mA

1 ... 6 V < 5 mA

1 ... 10 V < 5 mA

4 ... 20 mA < 20 mA

Ratiometric < 4 mA

Electrical connections / Protection standard

See order code selection table

Tests / Admissions

Shock acc. IEC 68-2-27

100 G, 11 ms half sine wave, all 6 directions. Free fall from 2 m on concrete (6x).

Constant shock acc. IEC 68-2-29

40 G for 6 ms, 1000 x all 3 directions.

Vibration acc. IEC 68-2-6

20 G, 9 ... 2000 Hz, 2 ... 9 Hz with amplitude +/- 15 mm, 1 Octave/min. all 3 directions, 50 constant load.

EMC-Behaviour see page 8

UL according to standard 873

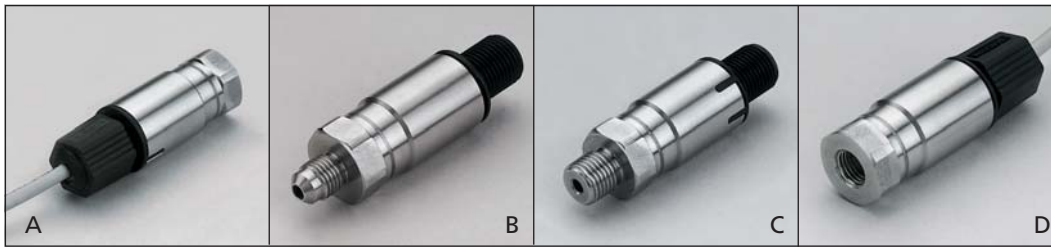

Versions

- A – Cable 1.5 meters
- B – Outside thread 7/16-20 UNF
- C – Outside thread 1/4-18 NPT
- D – Inside thread 7/16-20 UNF Schrader

Order code selection table

510. X X X X X X X X X X

Relative pressure		9																			
Pressure range	Customer side (-1 ... 160 bar) (minimum 7 bar fs)																				
			X	X																	
Sealing materials	None (cell welded)																				
Calibration	Factory calibrated																				
Outputs and power supply	0 – 5 V 8.0 – 33.0 VDC 3-wire																				1
	0 – 6 V 8.0 – 33.0 VDC 3-wire																				6
	0 – 10 V 12.3 – 33.0 VDC 3-wire																				2
	0 – 10 V 24 VAC +/- 15% 3-wire																				7
	4 – 20 mA 8.0 – 33.0 VDC 2-wire																				3
	0.5 – 4.5 V ratiom. 5 VDC (4.75 – 5.25) 3-wire																				4
Electrical connections	Cable 1.5 m IP 67																				0
	Quickon including cable screwing, without cable IP 67																				1
Pressure connections ¹⁾	Inside thread G 7/16-20 UNF Schrader																				0
	Outside thread G 7/16-20 UNF																				2
	Outside thread 1/4-18 NPT																				3
Process connections	Stainless steel																				0
	Stainless steel, free of oil and grease																				3
Pressure range variation	Indicate W and state pressure range on order																				W

Accessories / Packaging

		Order-Number
Accessories	Quickon cable screwing (included in delivery)	107359
Packaging	Mention on order: <ul style="list-style-type: none"> • Single packaging / • multiple packaging (25 pcs) • Single packaging, accessories integrated • Multiple packaging (25 pcs), Quickon cable screwing enclosed 	

¹⁾ Other pressure connections and materials on request

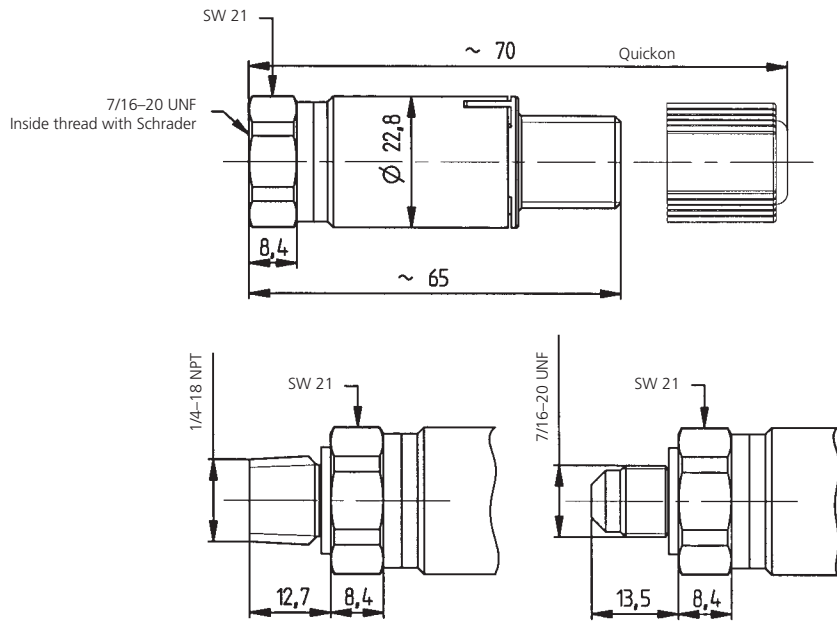

2-wire (4 – 20 mA)

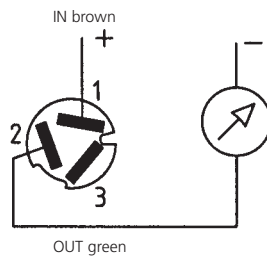

3-wire

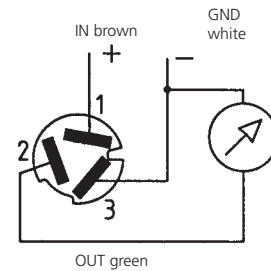

Electromagnetic compatibility: CE conformity (EMC) by application of harmonized standards: Interference stability EN 61000-6-2 and EN 61326-1, interference emit EN 61000-6-3 and EN 61326-1

	Test standard	Effect	
Interference stability			
Electrostatic discharge (ESD)	EN 61000-4-2	15 kV air, 8 kV contact	no effect
High-frequency electromagnetic radiation (HF)	EN 61000-4-3	30 V/m, 80 ... 1000 Mz	no effect
Conducted HF interference	EN 61000-4-6	30 V, 0.15 ... 80 MHz	no effect
Fast transients (burst)	EN 61000-4-4	4 kV	no effect
Surge	EN 61000-4-5	Line-Line, Line-Case	500 V, 12 Ohm, 9 µF
		Line-Case	1 kV, 42 Ohm, 0.5 µF
		Ratiometric Line-Line	500 V, 2 Ohm, 18 µF
Magnetic fields	EN 61000-4-8	30 A/m, 50 Hz	no effect
Insulation voltage		500 VDC	
		350 VAC	no effect
Interference emit			
Conducted interference	EN 55022 (CISPR 22)	0.15 ... 30 MHz	no emission
Radiation from housing		30 ... 1000 MHz, 10 m	no emission