

Pressure, vacuum and differential pressure transmitter

0 – 3 / 5 / 10 / 30 / 50 mbar

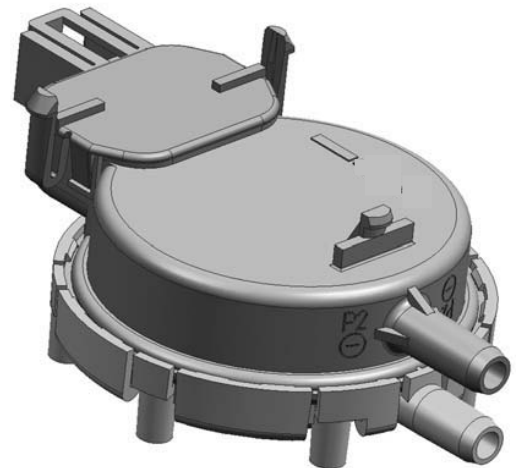
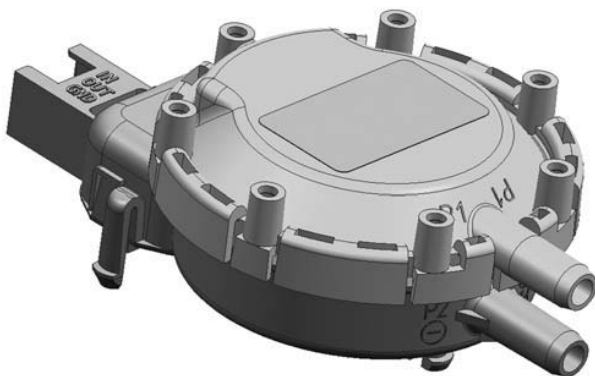
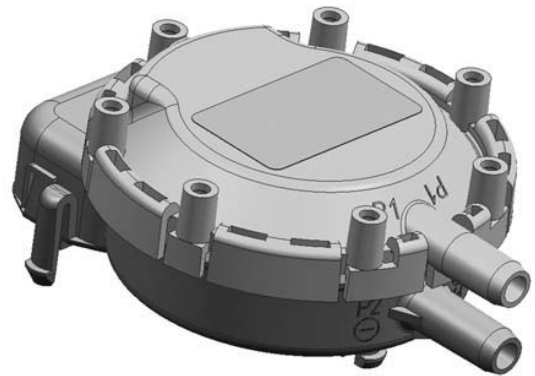

Technical overview

The differential pressure transmitters of type 402 with their proven ceramic fulcrum lever technology have calibrated, temperature-compensated sensor signals that are available with voltage outputs.

They are ideally suited for registering fine air flow in air conditioning technology and for measuring fine pressures in the environmental / medical technology sectors.

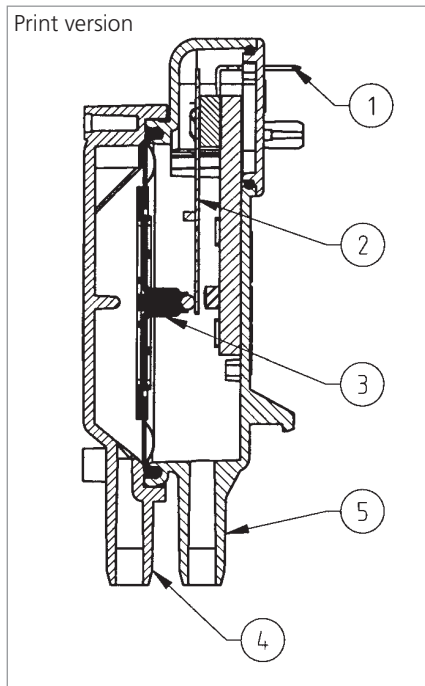

Legend to cross-section drawing

- 1 Electrical connection
- 2 Ceramic fulcrum lever with electronic circuitry
- 3 Diaphragm
- 4 Connection port P1
higher pressure/lower vacuum
- 5 Connection port P2
lower pressure /higher vacuum

The distinct advantages

- Attractive price / performance ratio
- Excellent synergy of diaphragm technology and ceramic elements
- Special adapter for top-hat rail mounting
- Direct pcb mounting with simple snap-on system

Medium

Air, neutral gases

Pressure ranges

Pressure ranges see order code selection table, other pressure ranges on request.

Tolerable overload

100 mbar

Rupture pressure

200 mbar at room temperature
150 mbar at 70 °C

Case construction

Polycarbonate PC / Polyamide PA

Diaphragm

Silicone

Accuracy

Medium and ambient temperature
0 ... 70 °C

TC sensitivity and TC zero point see parameter table

Storage temperature

- 30 ... + 70 °C

Dynamic response

Suitable for static and dynamic measurements.

Response time: < 10 ms

Load cycle: < 10 Hz

Weight

approx. 28 g

Installation arrangement

Diaphragm vertical, pressure connections facing downward,
diaphragm horizontal, P1 upwards

Adjusting position see order code selection table

Power supply / Output

Power supply 12 V (10.2 – 33.0 VDC)
Output 0.5 – 4.5 VDC

Load

> 15 kOhm (to GND)

Protection standard

IP 00

Current consumption

max. 8 mA

Electrical connections

Solderable pin on circuit board

3-pole plug connector RAST 2.5 mm
(AMP / Lumberg / Stocko)

Adapter plate

Phase-reversal protection: Connector and pcb version protected mechanically.

Packaging

In cartons with blister inserts, returnable

Accessories

See order code selection table
(supplied loose with consignment)

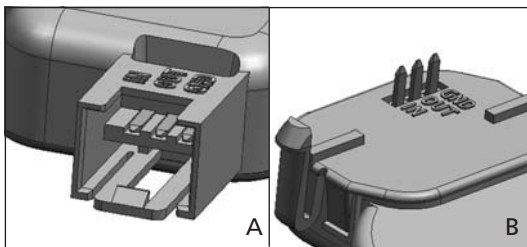

Versions

A – Connector version

B – Print version (for soldering customer sides)

Accuracy

Transmitter-Type Parameter	Unit	0 ... 3 mbar	0 ... 5 mbar	0 ... 10 mbar	0 ... 30 mbar	0 ... 50 mbar
Zero point ¹⁾ (at 0.5 V)	V	+/- 0.025	+/- 0.025	+/- 0.025	+/- 0.025	+/- 0.025
Final value ¹⁾ (at 4.5 V)	V	+/- 0.050	+/- 0.050	+/- 0.050	+/- 0.025	+/- 0.025
Linearity typ.	% fs	+/- 0.3	+/- 0.3	+/- 0.2	+/- 0.2	+/- 0.2
Linearity max.	% fs	+/- 0.5	+/- 0.5	+/- 0.3	+/- 0.3	+/- 0.3
Hysteresis typ.	% fs	0.2	0.2	0.2	0.1	0.1
Hysteresis max.	% fs	0.5	0.4	0.3	0.2	0.2
Long-term stability ²⁾	% fs	+/- 1.0	+/- 1.0	+/- 1.0	+/- 1.0	+/- 1.0
TC zero point ³⁾ typ.	% fs/K	+/- 0.02	+/- 0.02	+/- 0.02	+/- 0.02	+/- 0.02
TC zero point ³⁾ max.	% fs/K	+/- 0.04	+/- 0.04	+/- 0.04	+/- 0.04	+/- 0.04
TC sensitivity ³⁾ typ.	% fs/K	+/- 0.03	+/- 0.03	+/- 0.02	+/- 0.02	+/- 0.02
TC sensitivity ³⁾ max.	% fs/K	+/- 0.06	+/- 0.05	+/- 0.04	+/- 0.04	+/- 0.04
Positional error ¹⁾	mbar	approx. -0.13	approx. -0.13	approx. -0.13	approx. -0.13	approx. -0.13

Test conditions: 25 °C, 45 % RH
TC z. p. / TC s. 0–70 °C

Order code selection table

		402.	9	X	X	X	X	X	X
Pressure ranges ¹	0 ... + 3 mbar		1						
	0 ... + 5 mbar		2						
	0 ... + 10 mbar		3						
	0 ... + 30 mbar		4						
	0 ... + 50 mbar		5						
Adjusting position	Diaphragm vertical, pressure connections downwards			0					
	Diaphragm horizontal, P1 upwards			1					
Diaphragm	Silicone				0				
Output and power supply	0.5 ... 4.5 V 12 VDC (10.2 ... 33 VDC)						0		
Electrical connections	Print version								1
	Connector version (RAST 2.5 mm)								2
	For direct pcb mounting, mounted and soldered on adapter plate (compatible for types 696/697)								3
Pressure connection	Pipe Ø 6.2								1

Accessories

Fixing screw for wall thickness	1 – 2 mm	Length of screw	6 mm	1	0	2	9	7	6
	4.1 – 6 mm		10 mm	1	0	2	9	7	8
AMP Connector with cable (1m)				1	0	1	8	1	7
Base plate for rail mounting suitable for bearing rail TS 35				1	1	0	6	5	6
Bracket				1	0	8	2	2	2
Adapter (compatible for types 696/697)				1	1	0	9	1	0
Connecting cable for connector version (compatible for types 696/697)				1	1	1	7	0	7
AMP Connector	Manufacturer's Part No.	Colour	for cable						
	3-829868-3	grey	7-wire						0.22 – 0.25 mm ² or
			12-wire						0.32 – 0.35 mm ²
	1-966194-3	beige	7-wire						0.32 – 0.35 mm ²

1) For changing diaphragm position from horizontal to vertical, approx. -13 Pascal

2) Long-term stability acc. to DIN IEC 770

3) TC = Temperature coefficient

4) Other pressure ranges on request

